IR Intelligent Speed Dome Installation Manual

Version 1.0.1

Table of Contents

| | | |
|----------|---|-----------|
| 1 | IR INTELLIGENT SPEED DOME INSTALLATION | 1 |
| 1.1 | Installation Preparation | 1 |
| 1.2 | Check Accessories | 2 |
| 1.3 | Open the Device | 2 |
| 1.4 | Dial Switch Setup (Analog Speed Dome) | 2 |
| 1.4.1 | Initial Setup | 3 |
| 1.4.2 | Dial Setup for Intelligent Speed Dome | 3 |
| 1.4.3 | Baud Rate and Parity Setup | 3 |
| 1.4.4 | Speed Dome Address Setup | 4 |
| 1.5 | Dial Switch Setup (HDCVI Intelligent Speed Dome) | 4 |
| 1.5.1 | Initial Setup | 4 |
| 1.5.2 | Dial Setup for Intelligent Speed Dome | 4 |
| 1.5.3 | Baud Rate and HD/SD Video Format Setup | 5 |
| 1.5.4 | Speed Dome Address Setup | 5 |
| 1.6 | Reset and SD Card Installation (Network Speed Dome) | 6 |
| 1.7 | Speed Dome Installation | 7 |
| 1.7.1 | Install Quick Installation Connector | 7 |
| 1.7.2 | Cable Connection | 8 |
| 1.7.3 | Install the speed dome..... | 8 |
| 2 | BRACKET DIMENSIONS..... | 11 |
| 2.1 | Wall Mount Bracket..... | 11 |
| 2.2 | Hanging Mount Bracket (Multiple Lengths)..... | 11 |
| 2.3 | Corner Mount Bracket | 12 |
| 2.4 | Pole Mount Bracket..... | 13 |
| 3 | WALL MOUNT BRACKET INSTALLATION..... | 15 |
| 3.1 | Component Installation | 15 |
| 3.2 | Installation | 15 |
| 3.2.1 | Installation Requirements | 15 |
| 3.2.2 | Installation Steps | 15 |

| | | |
|-----------|--|-----------|
| 4 | HANG MOUNT BRACKET INSTALLATION..... | 17 |
| 4.1 | Component Installation | 17 |
| 4.2 | Installation | 17 |
| 4.2.1 | Installation Requirements | 17 |
| 4.2.2 | Installation Steps | 17 |
| 5 | CORNER MOUNT BRACKET INSTALLATION..... | 20 |
| 5.1 | Component Installation | 20 |
| 5.2 | Installation | 20 |
| 5.2.1 | Installation Requirements | 20 |
| 5.2.2 | Installation Steps | 20 |
| 6 | POLE MOUNT BRACKET INSTALLATION..... | 23 |
| 6.1 | Installation | 23 |
| 6.1.1 | Installation Requirements | 23 |
| 6.1.2 | Installation Steps | 23 |
| 7 | APPENDIX I LIGHTNING PROOF AND SURGE PROTECTION..... | 26 |
| 8 | APPENDIX II ABOUT RS485 BUS..... | 27 |
| 8.1 | RS485 Bus Main Feature | 27 |
| 8.2 | RS485 Bus Transmission Distance..... | 27 |
| 8.3 | The Problem in Practical Use | 27 |
| 8.4 | RS485 Bus FAQ..... | 28 |
| 9 | APPENDIX III THE RELATIONSHIP BETWEEN THE 24V AC CABLE DIAMETER AND THE TRANSMISSION DISTANCE | 29 |
| 10 | APPENDIX IV THE RELATIONSHIP BETWEEN THE 12V DC CABLE DIAMETER AND THE TRANSMISSION DISTANCE | 31 |
| 11 | APPENDIX IV WIRE GAUGE REFERENCE SHEET | 33 |

Welcome

Thank you for purchasing our speed dome!

Please read the following safeguards and warnings carefully before you install or use the product!

Important Safeguards and Warnings

Safety Measures

1. Qualified Engineer Needed

- The installation engineer or maintenance engineer shall have corresponding CCTV system installation certificate or maintenance qualification certificate.
- The installation engineer or maintenance engineer shall have qualification certificate for work at height.
- The installation engineer or maintenance engineer shall have the basic knowledge and operation technique for low-voltage cable layout and low-voltage electronic cable connection.
- Please read the installation manual carefully and keep it well for future reference,
- We are not liable for any problems caused by unauthorized modifications or attempted repair.

2. Lifting Appliance Requirement

- Please select the proper speed dome installation mode and use the lifting appliances at the safety environment.
- The lifting appliances shall have the enough capacity to reach the installation height.
- The lifting appliances shall have safe performance.

The precaution measures include two types: Warning and Note.

- **Warning:** It is to alert you there is an optional risk of death or series injury!
- **Note:** It is to alert you there is an optional risk of damage or property loss!

Warning

1. All installation and operation here should conform to your local electrical safety codes.
2. The power shall conform to the requirement in the SELV (Safety Extra Low Voltage) and the rated voltage conformed to Limited Power Source according to the IEC60950-1. (Power supply requirement is subject to the device label).
3. We assume no liability or responsibility for all the fires or electrical shock caused by improper handling or installation.
4. Be sure to use all the accessories (such as power adapter) recommended by manufacturer.
5. Laser light is dangerous; please do not look at it straight.
6. Do not connect several speed domes to one power adapter. It may result in overheat or fire if it exceeds the rated load.

-
7. Before you connect the cable, install or uninstall, or begin the daily maintenance work, please turn off the power and unplug the power cable.
 8. Please make sure the produce is secure firmly on the wall or the ceiling.
 9. Please turn off the power and unplug the power cable, If there is any smoke, disgusting smell, or noise. Please contact your local retailer or customer service centre for help.
 10. All the examination and repair work should be done by the qualified service engineers. We are not liable for any problems caused by unauthorized modifications or attempted repair.

Note

1. Safety Transportation

- Heavy stress, violent vibration or water splash are not allowed during transportation, storage and installation.
- This series product must use split type package during the transportation.
- We are not liable for any damage or problem resulting from the integrated package during the transportation.

2. When device is malfunction

Shut down the device and disconnect the power cable immediately if there is smoke, abnormal smell or abnormal function. Please contact your local retailer ASAP.

3. Do not try to dismantle or modify the device

- There is risk of personal injury or device damage resulting from opening the shell.
- Please contact your local retailer if there is internal setup or maintenance requirement.
- We are not liable for any problems caused by unauthorized modifications or attempted repair.

4. Do not allow other object falling into the device

- Please make sure there is no metal or inflammable, explosive substance in the speed dome.
- The above mentioned objects in the device may result in fire, short-circuit or damage.
- Please shut down the device and disconnect the power cable if there is water or liquid falling into the camera. Please contact your local retailer ASAP.
- Please pay attention to the camera. Avoid the sea water or rain to erode the camera.

5. Handle carefully

Do not allow this series product fall down to the ground.
Avoid heavy vibration.

6. Installation Environment Requirement

- This series speed dome should be installed in a cool, dry place away from direct sunlight, inflammable, explosive substances and etc.
- This series product shall be away from the strong electromagnetism radiant, please keep it away from wireless power, TV transmitter, transformer and etc.

7. Daily Maintenance

- Please use the soft cloth to clean dust on the shell, or you can use soft cloth with cleaning liquid to clean the shell and then use soft cloth to make it dry.
- Do not use gasoline, dope thinner or other chemical material to clean the shell. It may result in shell transfiguration or paint flake.
- Do not allow the plastic or rubber material to touch the shell for a long time. It may result in paint flake.
- It is highly recommended to use the product with a lightning-proof device, which can realize better lightning-proof effect.

1 IR INTELLIGENT SPEED DOME INSTALLATION

1.1 Installation Preparation

Basic Requirement

- All installation and operation here should conform to your local electrical safety codes.
- Before installation, please open the package and check all the components are included. Please make sure the speed dome installation environment and installation mode can meet your requirement. If there is special requirement, please contact your local retailer for more information.
- We assume no liability or responsibility for all the fires or electrical shock caused by improper handling or installation.

Check installation space and installation location intension

Please make sure the installation environment has enough space to install the speed dome and its corresponding bracket.

Please make sure the ceiling, wall and the bracket can support the speed dome and its corresponding installation component. It shall sustain the 8X weight of the speed dome. Please notice that the installation height should be more than 6m if it is a laser speed dome.

About cable

Please select the cable according to your transmission distance.

The minimum video coaxial-cable requirement is:

- 75 ohm.
- Full cable with copper conductor
- 95% knitted copper shield
- RS485 communication cable, please refer to appendix 2.

| International Model | Max Distance (Ft/M) |
|---------------------|---------------------|
| RG59/U | 750ft (229m) |
| RG6/U | 1,000ft (305m) |
| RG11/U | 1,500ft (457m) |

Note:

The above can be applied to analog speed dome and network speed dome.

| International Model | Max distance (Ft/M) |
|---------------------|---------------------------------|
| SYV-75-3 | 720P (25fps\30fps): 500M/1640ft |
| | 720P (50fps\60fps): 300M/984ft |
| | 1080P (25fps\30fps): 300M/984ft |

Note:

The above can be applied to HDCVI speed dome.

Select proper power supply cable according to transmission distance

Refer to appendix 3 for 24VAC power supply device.

Refer to appendix 4 for 12VDC power supply device.

Please keep all package material well for future use

Please keep speed dome package material well in case you need to send it back to your local retailer or manufacturer for maintenance work.

Non-original package material may result in device damage during the transportation.

1.2 Check Accessories

Before the installation, please check the accessories one by one according to the packing list. Please make sure all the components listed are includes.

1.3 Open the Device

Please open the box and then take out the speed dome. See Figure 1-1.

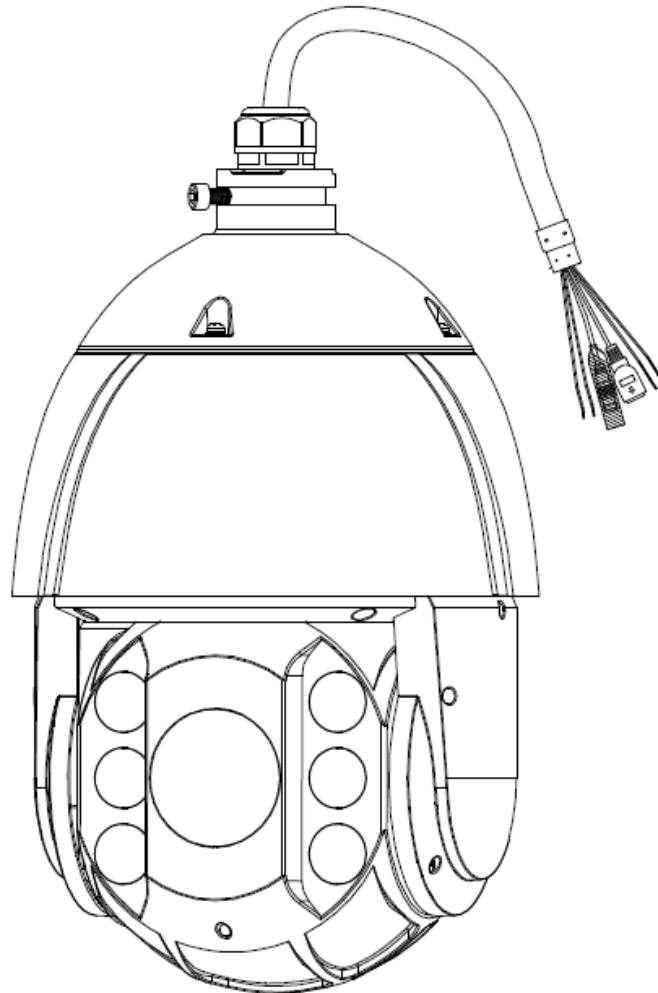

Figure 1-1

1.4 Dial Switch Setup (Analog Speed Dome)

Open the cover of the speed dome; you can see there is a dial switch which can be used to set the intelligent speed dome address, Baud rate, parity and etc.

1.4.1 Initial Setup

- Address: 1
- Baud rate: 9600
- Parity: None

1.4.2 Dial Setup for Intelligent Speed Dome

Users must set the address number, Baud rate and parity which are used by the speed dome before controlling it. Only after all these setup, can the speed dome respond to its control commands.

Note:

It has to reboot to make the new setup valid after relevant info being reset.

There is a dial switch in the back cover of the speed dome, which is used to confirm the speed dome address, Baud rate and parity. When the switch is moved to ON as 1, then 1 is the lowest bit and 8 is the highest bit in the address setup dial; in the Baud rate and parity setup dial, 1 is the lowest bit and 4 is the highest bit, as it is shown in Figure 1-2. (Intelligent speed dome can self-adapt PELCO-D; PELCO-P, and industrial standard protocol, control protocol doesn't need to be realized via dial setup).

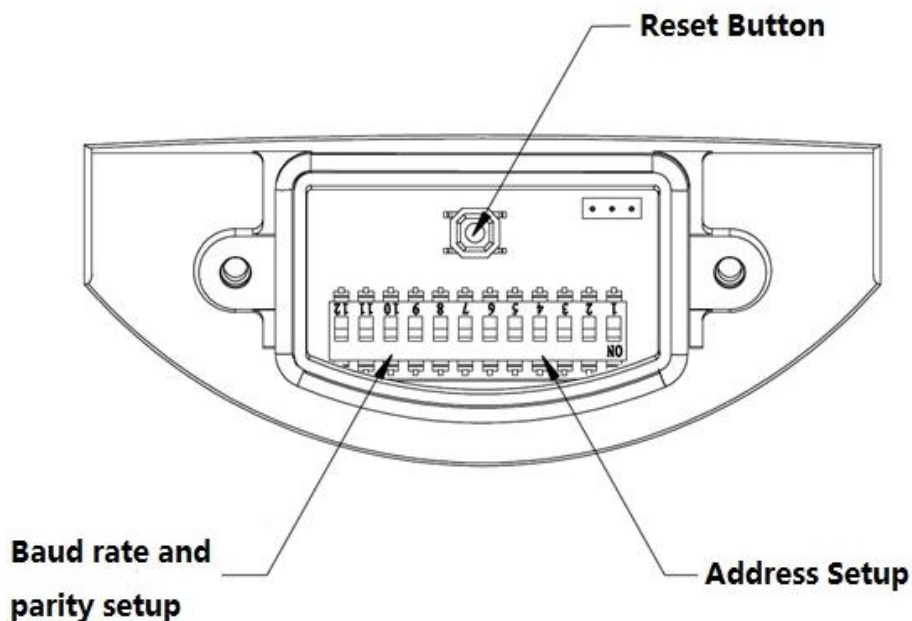

Figure 1-2

1.4.3 Baud Rate and Parity Setup

It is to set the speed dome Baud rate and parity. From bit 9 to 12, bit 9 and 10 are used to set Baud rate, and bit 11 and 12 are used to set parity. Please refer to sheet 1-1 and 1-2 respectively.

| 9 | 10 | Baud rate |
|-----|-----|-----------|
| OFF | OFF | 9600bps |
| ON | OFF | 4800bps |
| OFF | ON | 2400bps |
| ON | ON | 1200bps |

Sheet 1-1

| | | |
|-----|-----|--------|
| 11 | 12 | Parity |
| OFF | OFF | NONE |
| ON | OFF | EVEN |
| OFF | ON | ODD |
| ON | ON | NONE |

Sheet 1-2

1.4.4 Speed Dome Address Setup

The speed dome uses dial switch to set address, the encode mode adopts binary system. 1 to 7 is valid bit. The highest address bit is 255. You can refer to the following sheet 1-3 for more information.

| Address | 1 | 2 | 3 | 4 | 5 | 6 | 7 | 8 |
|---------|-------|-----|-----|-----|-----|-----|-----|-----|
| 1 | OFF | OFF | OFF | OFF | OFF | OFF | OFF | OFF |
| 1 | ON | OFF | OFF | OFF | OFF | OFF | OFF | OFF |
| 2 | OFF | ON | OFF | OFF | OFF | OFF | OFF | OFF |
| 3 | ON | ON | OFF | OFF | OFF | OFF | OFF | OFF |
| 4 | OFF | OFF | ON | OFF | OFF | OFF | OFF | OFF |
| 5 | ON | OFF | ON | OFF | OFF | OFF | OFF | OFF |
| 6 | OFF | ON | ON | OFF | OFF | OFF | OFF | OFF |
| 7 | ON | ON | ON | OFF | OFF | OFF | OFF | OFF |
| 8 | OFF | OFF | OFF | ON | OFF | OFF | OFF | OFF |
| | | | | | | | | |
| 254 | OFF | ON | ON | ON | ON | ON | ON | ON |

Sheet 1-3

1.5 Dial Switch Setup (HDCVI Intelligent Speed Dome)

Open the cover of the speed dome; you can see there is a dial switch which can be used to set the intelligent speed dome address, Baud rate, HD/SD video format and etc.

Note:

When HDCVI intelligent speed dome only uses coaxial control, dial-up and other relevant RS485 setup don't have to be implemented.

1.5.1 Initial Setup

- Address: 1
- Baud rate: 9600
- HD/SD video format: HD

1.5.2 Dial Setup for Intelligent Speed Dome

Users must set the address number, Baud rate and HD/SD video format which are used by the speed dome before controlling it. Only after all these setup, can the speed dome respond to its control commands.

Note:

It has to reboot to make the new setup valid after relevant info being reset.

There is a dial switch in the back cover of the speed dome, which is used to confirm the speed dome address, Baud rate and HD/SD video format. When the switch is moved to ON as 1, then 1 is the lowest bit and 8 is the highest bit in the address setup dial; in the Baud rate and HD/SD

video format setup dial, 1 is the lowest bit and 4 is the highest bit, as it is shown in Figure 1-3. (Intelligent speed dome can self-adapt PELCO-D; PELCO-P, and industrial standard protocol, control protocol doesn't need to be realized via dial setup).

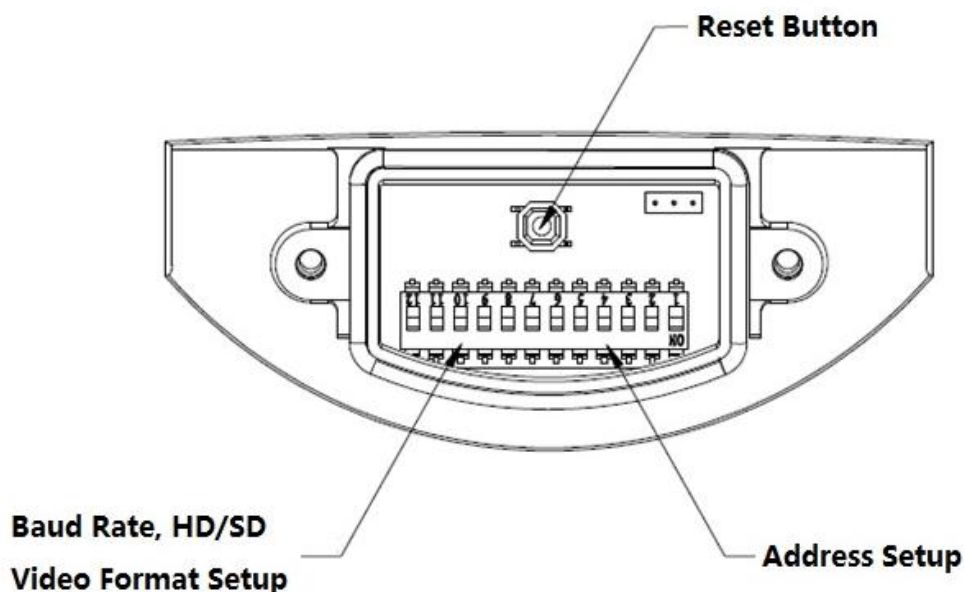

Figure 1-3

1.5.3 Baud Rate and HD/SD Video Format Setup

It is to set the speed dome Baud rate and HD/SD video format. From bit 9 to 12, bit 9 and 10 are used to set Baud rate, and bit 11 and 12 are used to set HD/SD video format. Please refer to sheet 1-4 and 1-5 respectively.

| 9 | 10 | Baud rate |
|-----|-----|-----------|
| OFF | OFF | 9600bps |
| ON | OFF | 4800bps |
| OFF | ON | 2400bps |
| ON | ON | 1200bps |

Sheet 1-4

| 11 | 12 | HD/SD video format |
|-----|-----|--------------------|
| OFF | OFF | HD |
| ON | OFF | SD |
| OFF | ON | Self-adaptive |
| ON | ON | HD |

Sheet 1-5

1.5.4 Speed Dome Address Setup

The speed dome uses dial switch to set address number, the encode mode adopts binary system. 1 to 8 is valid bit. The highest address bit is 255. You can refer to the following sheet 1-6 for more information.

| Address | 1 | 2 | 3 | 4 | 5 | 6 | 7 | 8 |
|---------|-----|-----|-----|-----|-----|-----|-----|-----|
| 1 | OFF | OFF | OFF | OFF | OFF | OFF | OFF | OFF |

| Address | 1 | 2 | 3 | 4 | 5 | 6 | 7 | 8 |
|---------|-------|-----|-----|-----|-----|-----|-----|-----|
| 1 | ON | OFF | OFF | OFF | OFF | OFF | OFF | OFF |
| 2 | OFF | ON | OFF | OFF | OFF | OFF | OFF | OFF |
| 3 | ON | ON | OFF | OFF | OFF | OFF | OFF | OFF |
| 4 | OFF | OFF | ON | OFF | OFF | OFF | OFF | OFF |
| 5 | ON | OFF | ON | OFF | OFF | OFF | OFF | OFF |
| 6 | OFF | ON | ON | OFF | OFF | OFF | OFF | OFF |
| 7 | ON | ON | ON | OFF | OFF | OFF | OFF | OFF |
| 8 | OFF | OFF | OFF | ON | OFF | OFF | OFF | OFF |
| | | | | | | | | |
| 254 | OFF | ON | ON | ON | ON | ON | ON | ON |
| 255 | ON | ON | ON | ON | ON | ON | ON | ON |

1.6 Reset and SD Card Installation (Network Speed Dome)

You can see there is a RESET button on the PCB after you open the cover; the reset button is used for network system reset. See Figure 1-4.

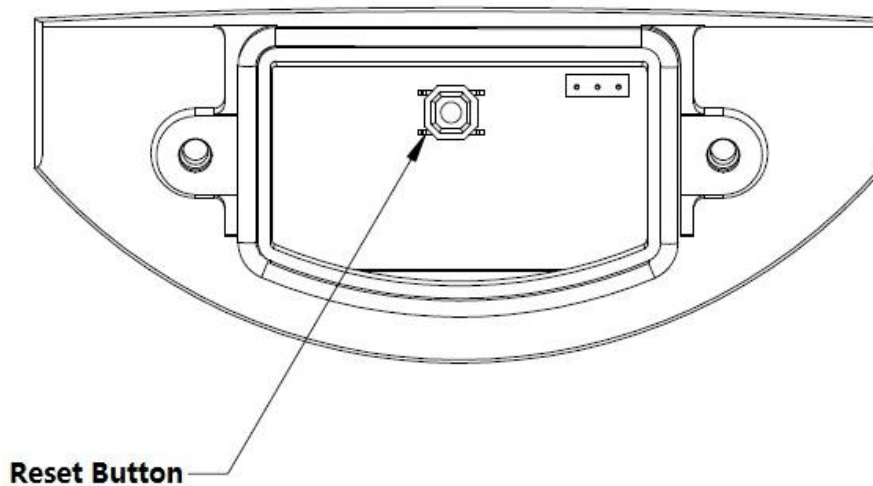

Figure 1-4

Micro-SD card is used to save the data. SD card slot is located on the control panel of the module; you can see it after you open the back cover, which is shown in Figure 1-5. Pay attention to the direction of Micro-SD card slot, first slightly press down the card slot towards OPEN direction (refer to the instructions on the card slot), it will become loose, then put the SD card into it, pay attention that the card's metal surface is corresponding to the golden finger of the card slot, then slightly press down the card slot and move towards the CLOSE direction.

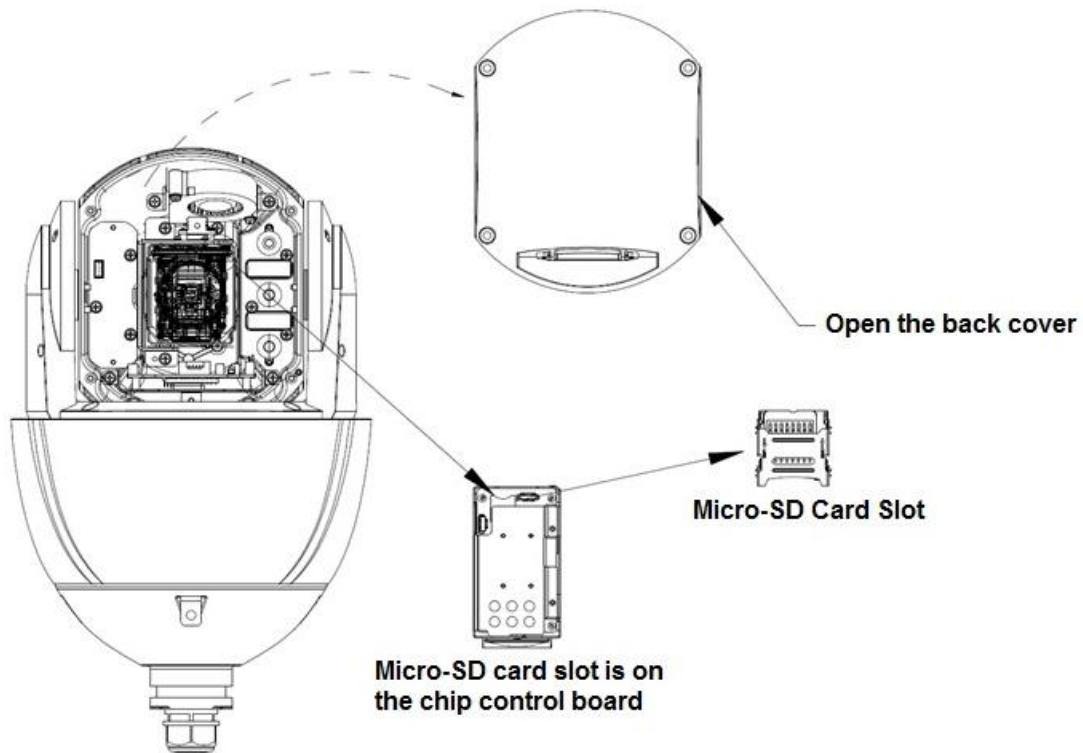

Figure 1-5

1.7 Speed Dome Installation

Note:

The installation of this section can be applied to IR Analog Intelligent and IR Network Intelligent Speed Dome.

The speed dome has various brackets suitable for different environments. For detailed information, please refer to chapter 1 to chapter 6. Here we are going to install the analog speed dome with the wall mount bracket.

1.7.1 Install Quick Installation Connector

Wind Teflon tape around the thread of the quick installation connector and screw it into the pipe thread of the wall mount bracket, and then use M4 stainless screw to fix it firmly, which is shown in Figure 1-6.

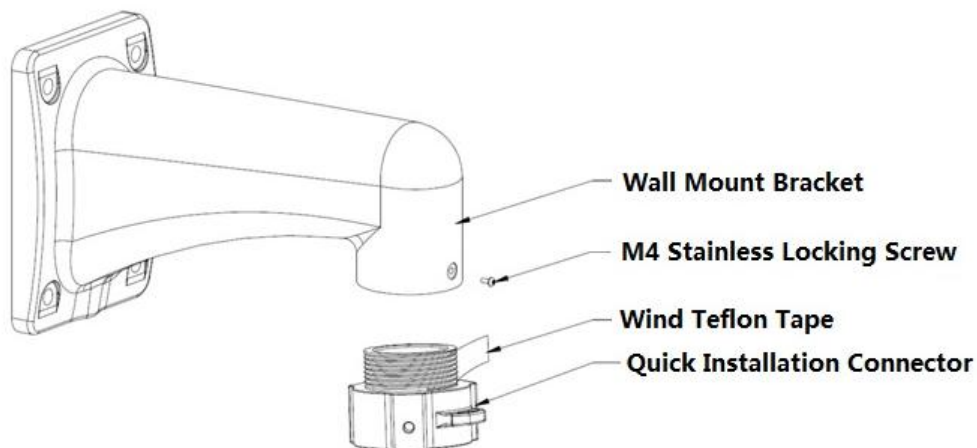

Figure 1-6

1.7.2 Cable Connection

Connect the safety hook of the IR speed dome to the wall mount bracket, connect the reserved integration cable of the wall mount bracket to the corresponding power cable, video/audio cable, RS485 control cable, alarm port, high frequency cable, fiber cable (if necessary) of the multiple-function composite cable of the IR speed dome. Paste the insulating tape in the connection position to do the proper waterproof work. See Figure 1-7.

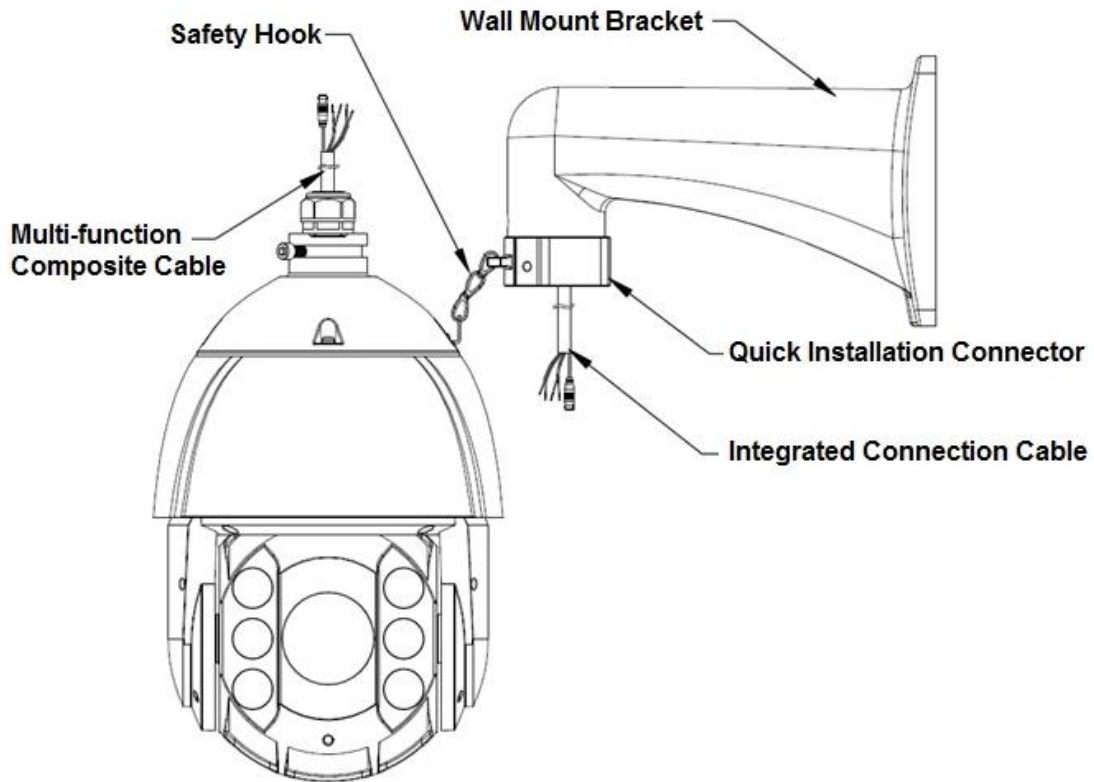

Figure 1-7

Note

The video port is covered the heat shrink tube of high shrinking ratio. After the video connection, please heat the tube to make sure the video port is damp proof and water proof.

1.7.3 Install the speed dome

Step 1

Pull the integration cable and multiple-function composite cable to the wall mount bracket slowly.

Step 2

Use the quick installation screw on the speed dome and the quick installation concave on the bracket to fix the speed dome on the bracket.

Step 3

Use three M6*14 stainless screws to the groove of the IR speed dome flange, use inner hex tool to tighten the three stainless screws, see Figure 1-8.

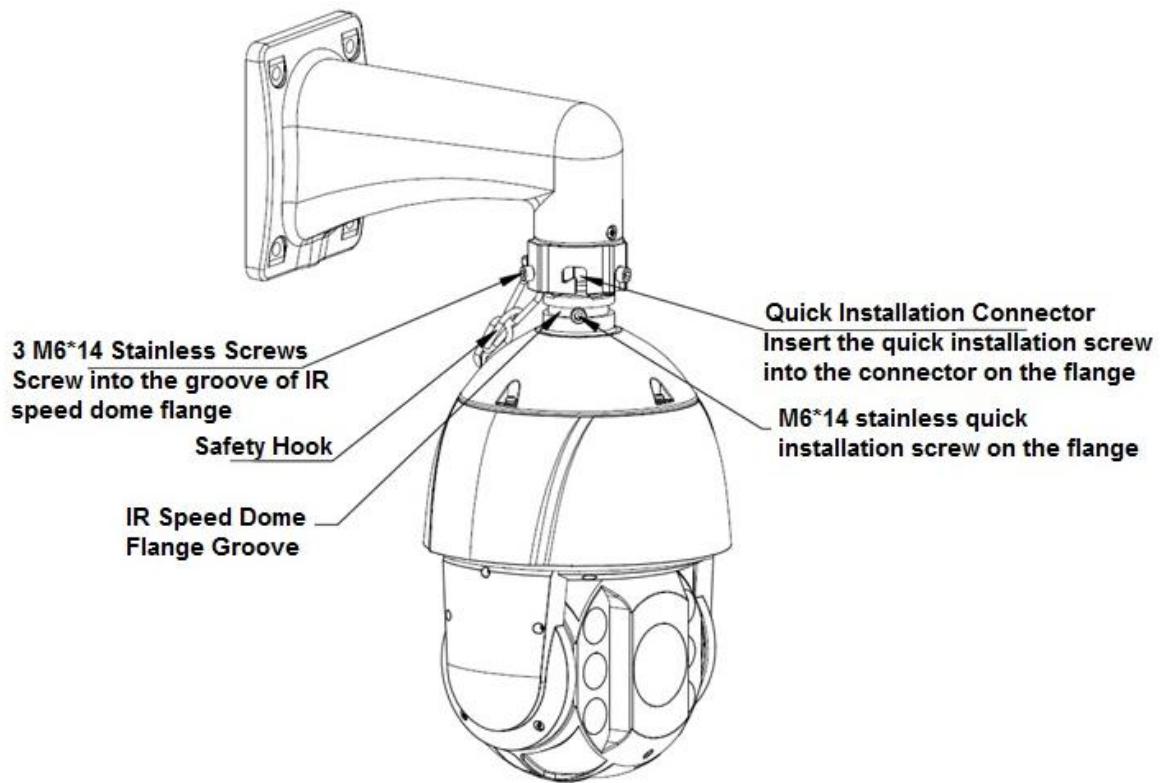

Figure 1-8

Step 4

Please make sure:

- The three stainless screws of the quick installation port are firmly secure.
- The IR speed dome is fixed.
- The speed dome is straight.
- The safety buckle connection is firm.

After your installation, the interface is shown as in Figure 1-9.

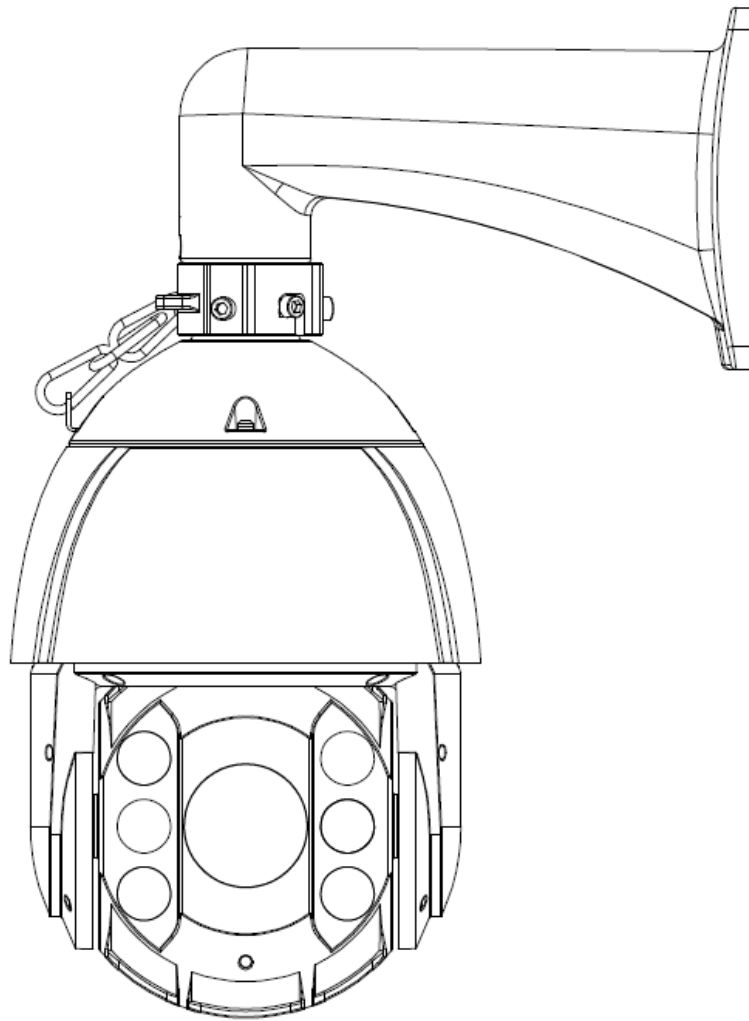

Figure 1-9

2 BRACKET DIMENSIONS

2.1 Wall Mount Bracket

The wall mount bracket dimensions are shown as below. See Figure 2-1.

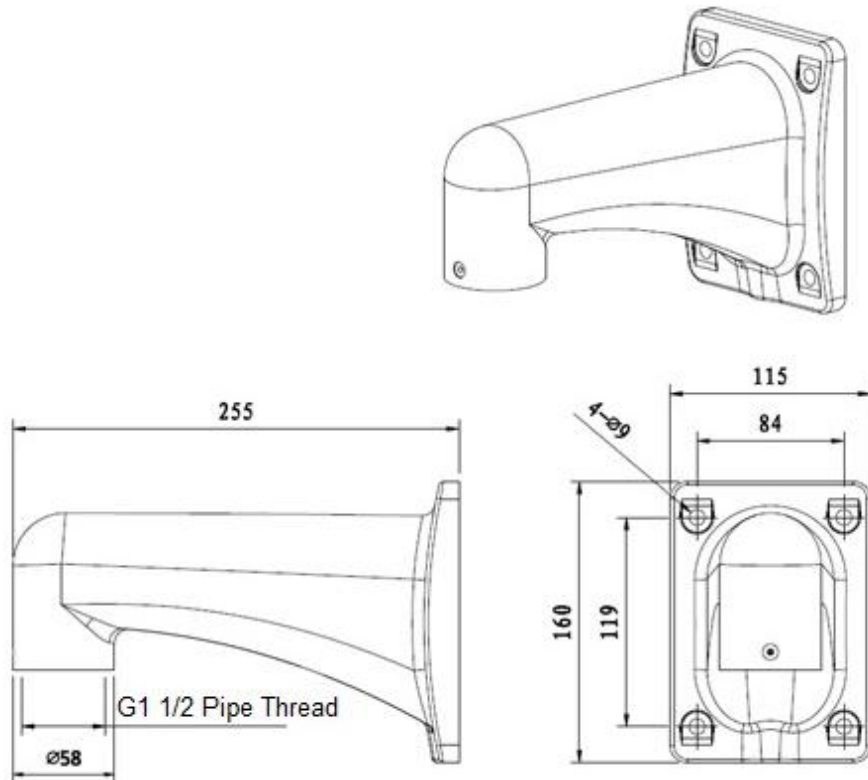

Figure 2-1

2.2 Hanging Mount Bracket (Multiple Lengths)

The hanging mount bracket is shown as below. See Figure 2-2.

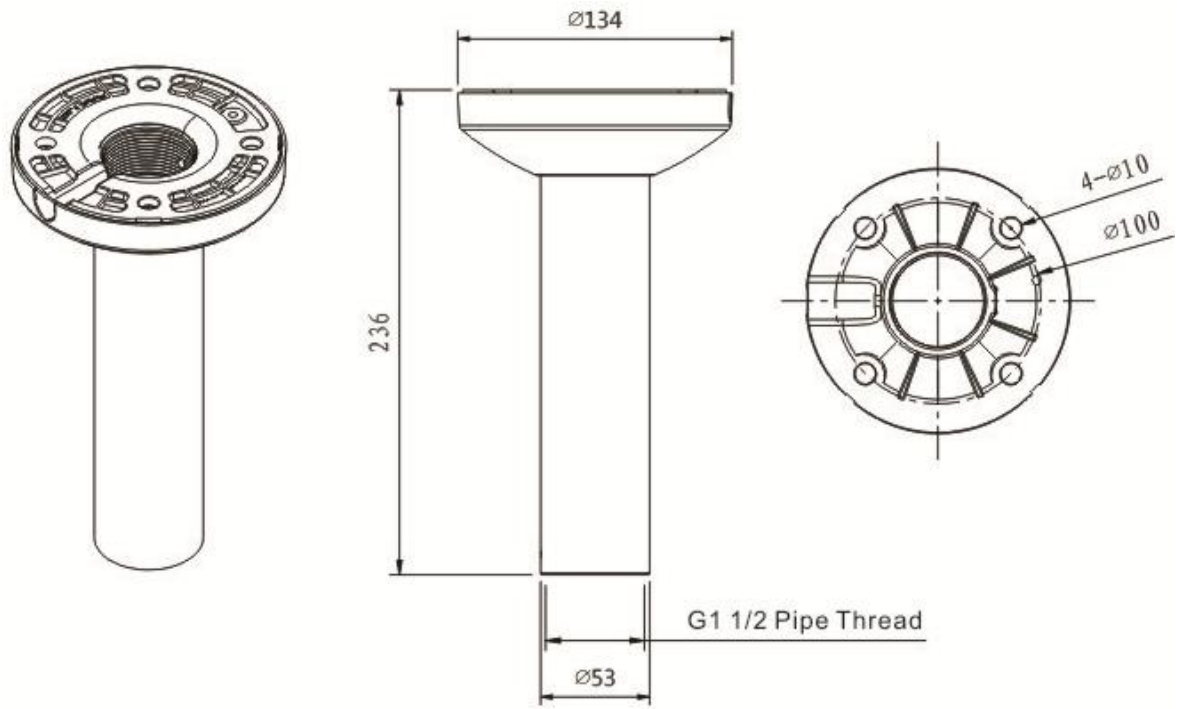

Figure 2-2

Note:

The bracket length setup values are:

200mm (default)

400mm (optional)

You just need to replace the connection pole

2.3 Corner Mount Bracket

The corner mount bracket is shown as below. See Figure 2-3.

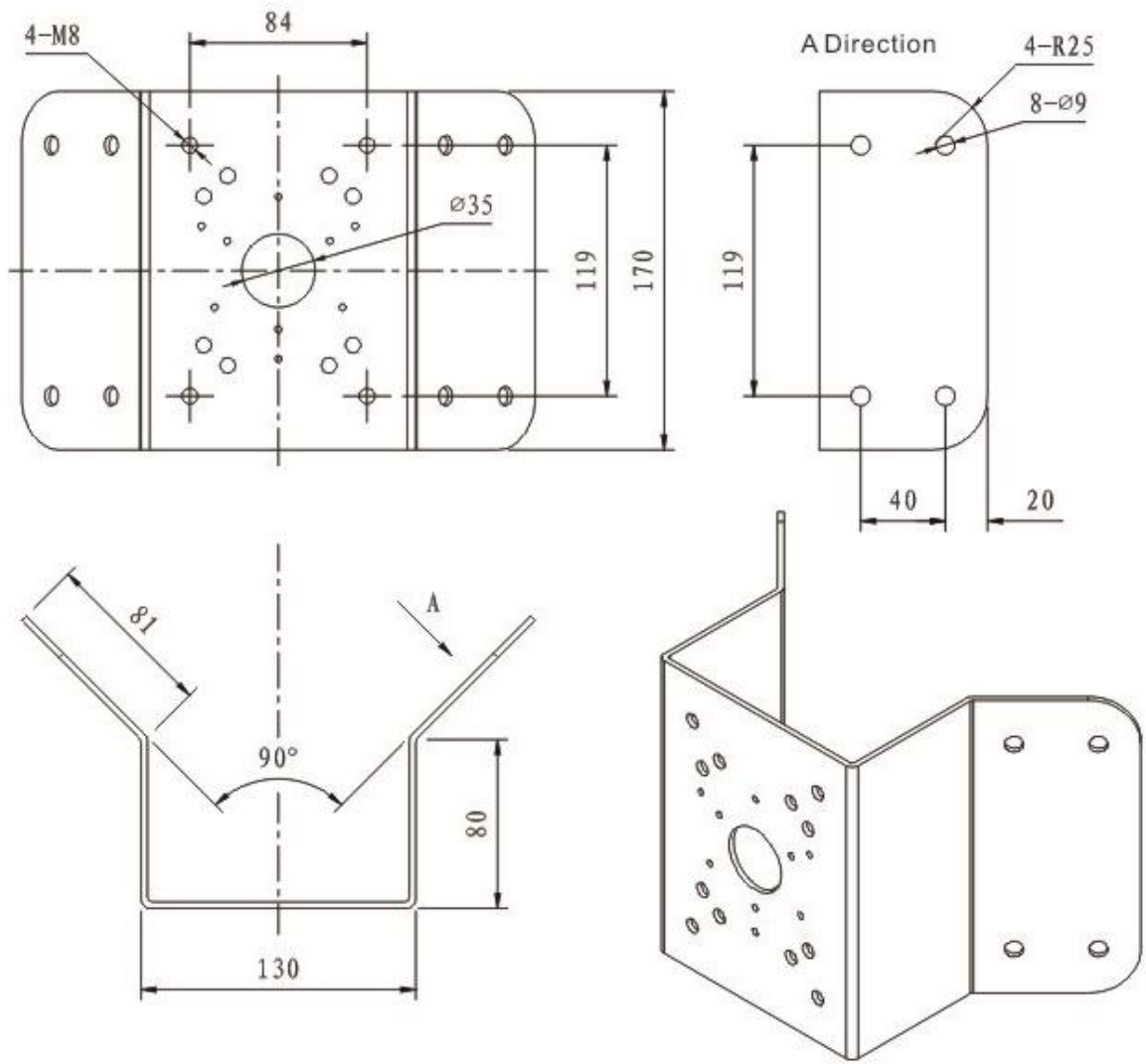

Figure 2-3

2.4 Pole Mount Bracket

The pole mount bracket is shown as below. See Figure 2-4.

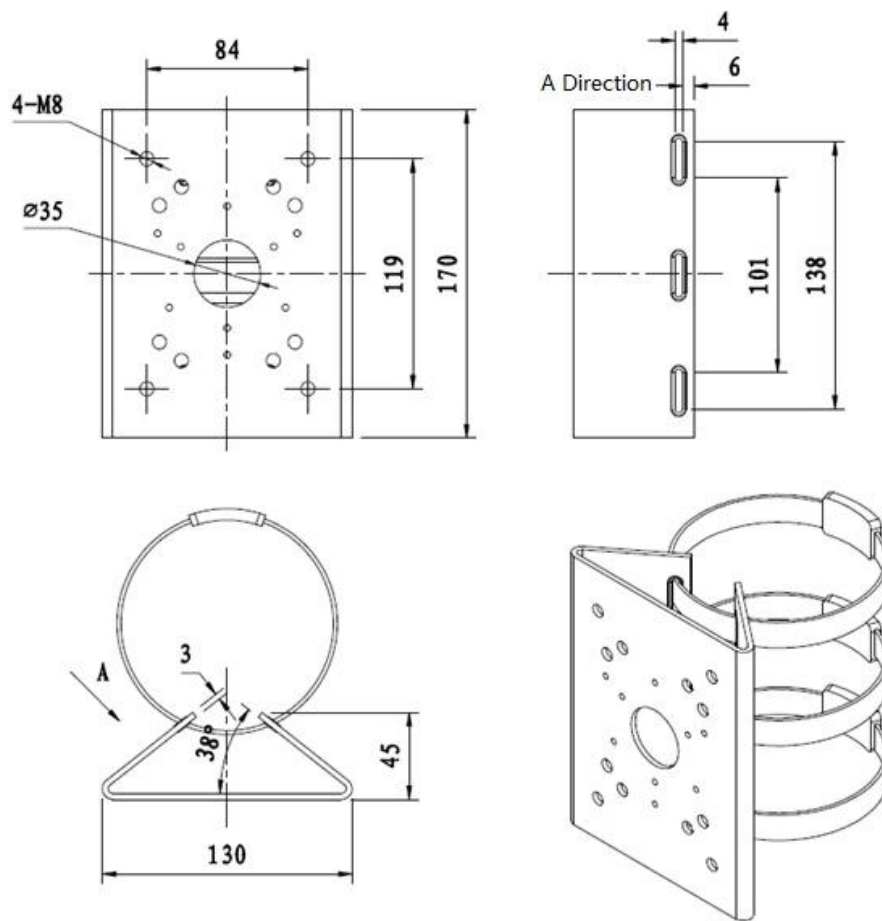

Figure 2-4

3 WALL MOUNT BRACKET INSTALLATION

3.1 Component Installation

Wall mount bracket is shown as below. See Figure 3-1.

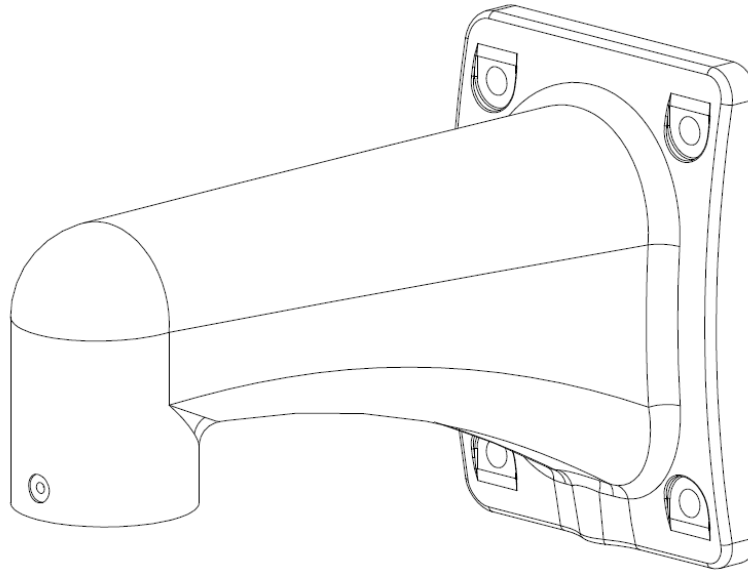

Figure 3-1

3.2 Installation

3.2.1 Installation Requirements

The wall mount speed dome can be installed in the hard construction wall in the indoor or outdoor environments. Before the installation, please make sure:

- The wall is thick enough to install the expansion bolt.
- The wall can at least sustain the 8x weight of the speed dome.

3.2.2 Installation Steps

Step 1

See Figure 3-2. Please draw four holes position in the wall according to the hole of the bottom of the wall mount bracket. Then you can dig four holes and insert the expansion bolts (not provided). Use four hex bolts and flat washer to fix the bracket in the expansion bolts.

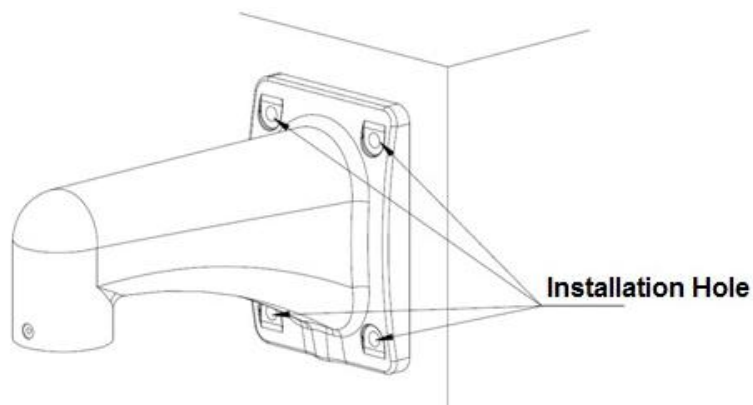

Figure 3-2

Step 2

Install the IR speed dome in the bracket. See Figure 3-3. Please refer to 1.6 Speed Dome Installation for more details.

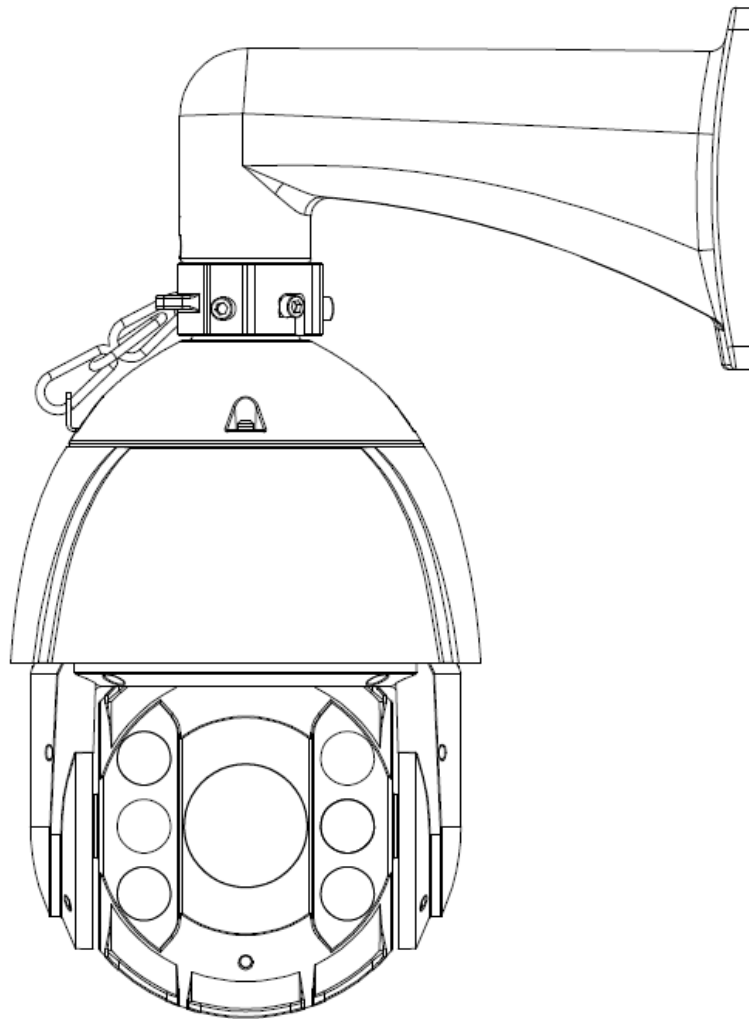

Figure 3-3

4 HANG MOUNT BRACKET INSTALLATION

4.1 Component Installation

Hang mount bracket and its components are shown as below. See Figure 4-1.

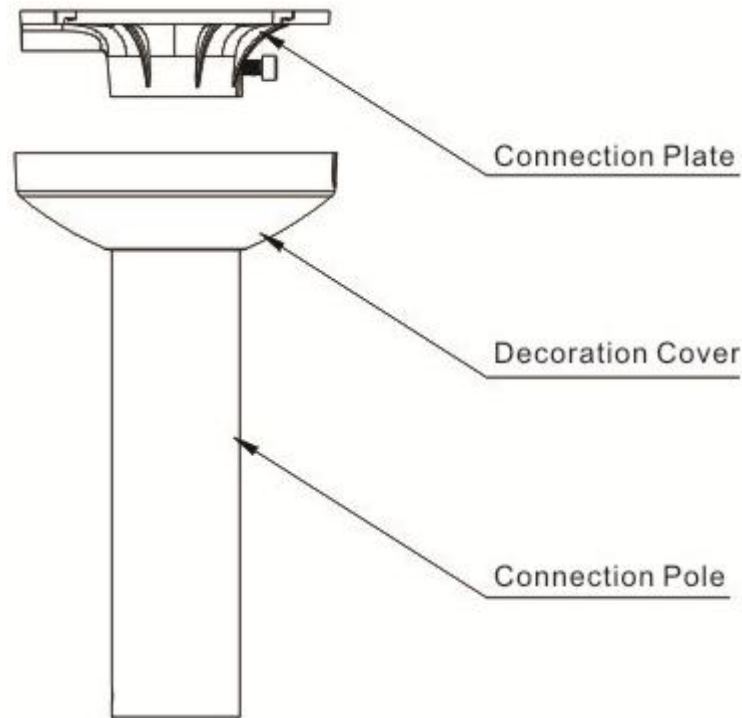

Figure 4-1

4.2 Installation

4.2.1 Installation Requirements

The hang mount speed dome can be installed in the hard construction wall in the indoor or outdoor environments. Before the installation, please make sure:

- The wall is thick enough to install the expansion bolt.
- The wall can at least sustain the 8x weight of the speed dome.

4.2.2 Installation Steps

Step 1

Loosen the M4 bolt in the connection plate to separate the connection plate and connection pole. Pull the integration cable through the airproof slot of the bottom of the connection plate and then connect to the centre hole of the flange. Please secure the connection plate in the ceiling. See Figure 4-2.

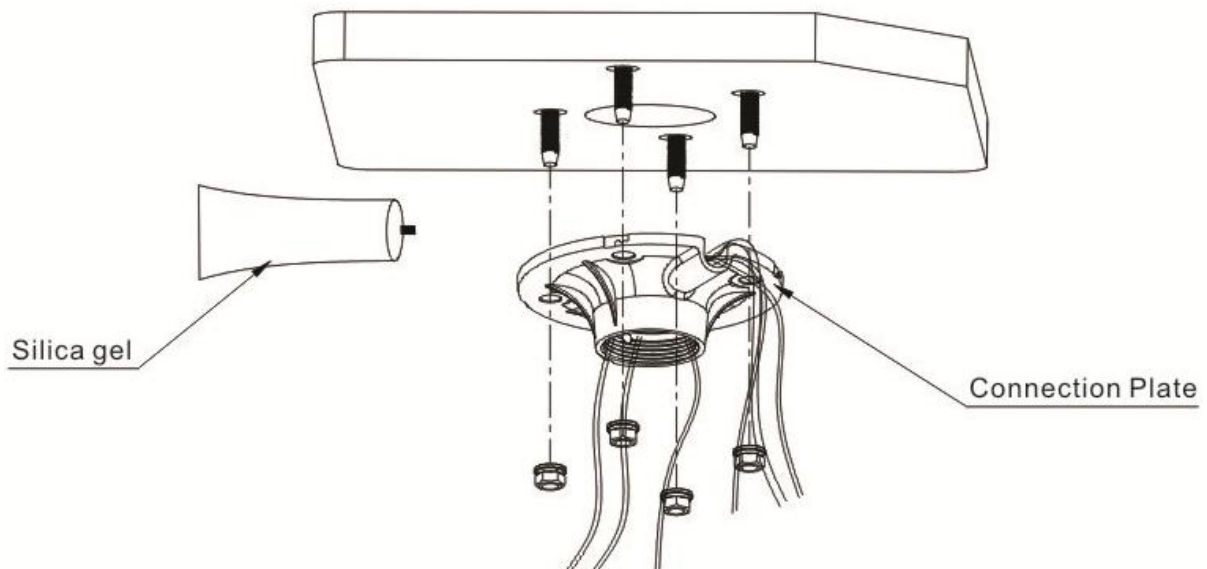

Figure 4-2

Please note, if the speed dome is installed in the outdoor environments, you need to paste the silica gel on the surface of the connection plate and the ceiling and the cable exit.

Step 2

Pull the cable through the connection pole and then secure the connection pole to the connection plate. Fix the M4 bolt. Push the decoration cover to the bottom. See Figure 4-3.

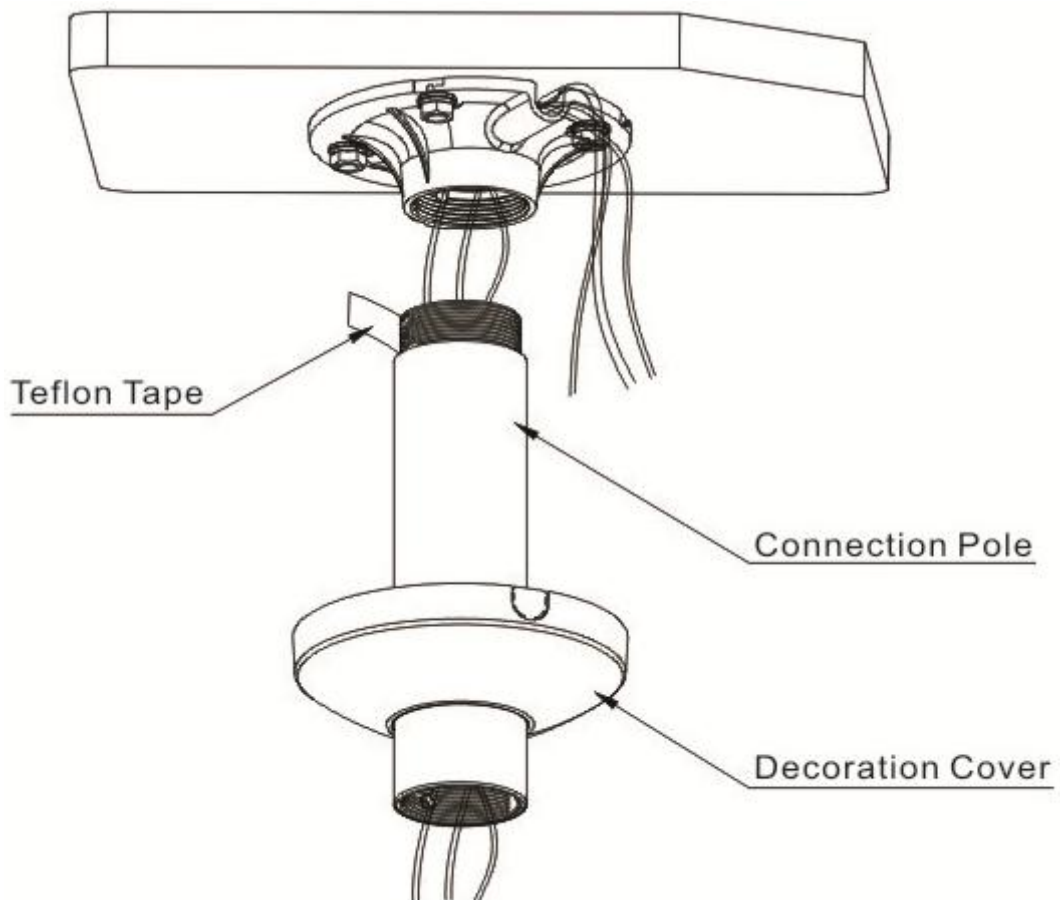

Figure 4-3

Please note, if the speed dome is installed in the outdoor environments, you need to paste enough Teflon tape at the top screw thread of the connection pole and then turn the connection pole to the connection plate firmly.

Step 3

Please refer to chapter 1.6 for detailed information about speed dome installation. See Figure 4-4.

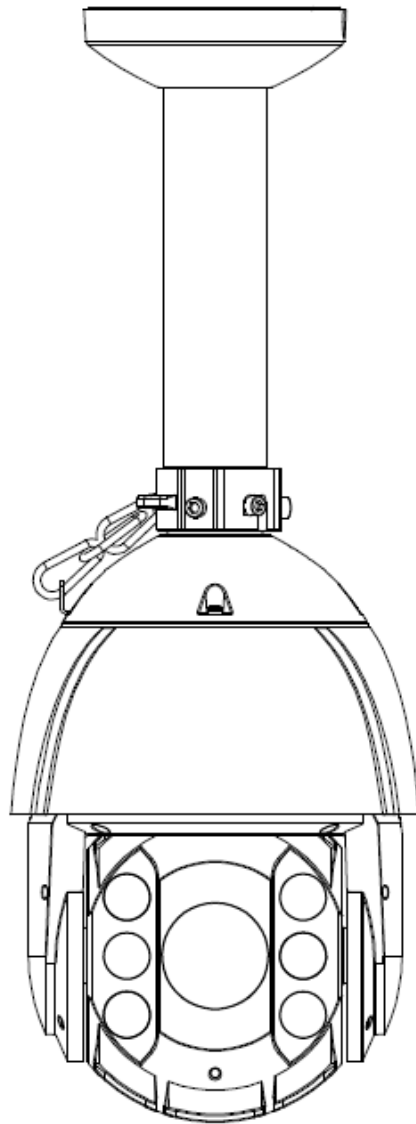

Figure 4-4

5 CORNER MOUNT BRACKET INSTALLATION

5.1 Component Installation

Corner mount bracket and its components are shown as below. See Figure 5-1.

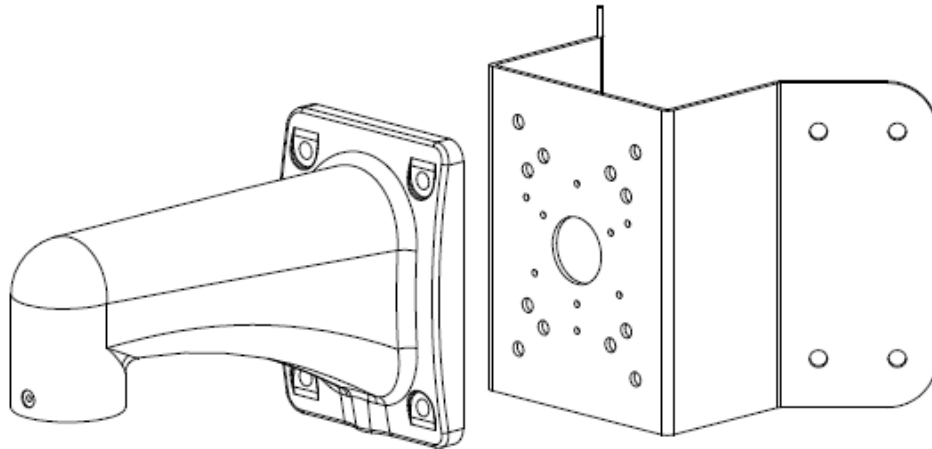

Figure 5-1

5.2 Installation

5.2.1 Installation Requirements

The corner mount speed dome can be installed in the hard construction wall in the indoor or outdoor environments where there is a 90 degrees angle. Before the installation, please make sure:

- The wall is thick enough to install the expansion bolt.
- The wall can at least sustain the 8x weight of the speed dome.

5.2.2 Installation Steps

Step 1

Please draw four holes position in the wall with a 90-degree angle according to the holes of the corner installation accessories. See Figure 5-2. Then you can dig four holes according to the holes of the corner mount accessories and insert the M8 expansion bolts. Pull the integration cable through the centre hole of the bottom of the corner bracket, the waterproof adhesive, and the centre of the bracket. Please reserve the enough cable connection length and then use the M8 expansion bolt to secure the corner mount bracket chassis on the wall.

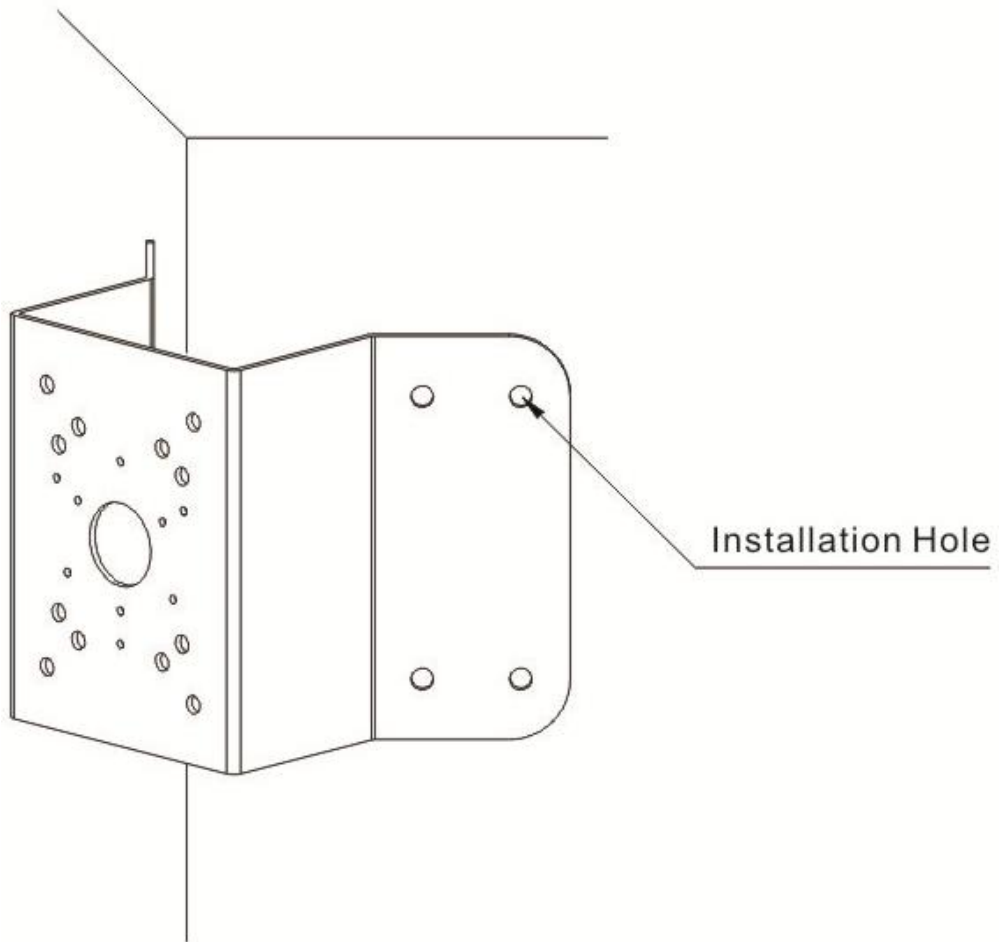

Figure 5-2

Step 2

Install speed dome according to Figure 5-3, please refer to 1.6 for more details about speed dome installation.

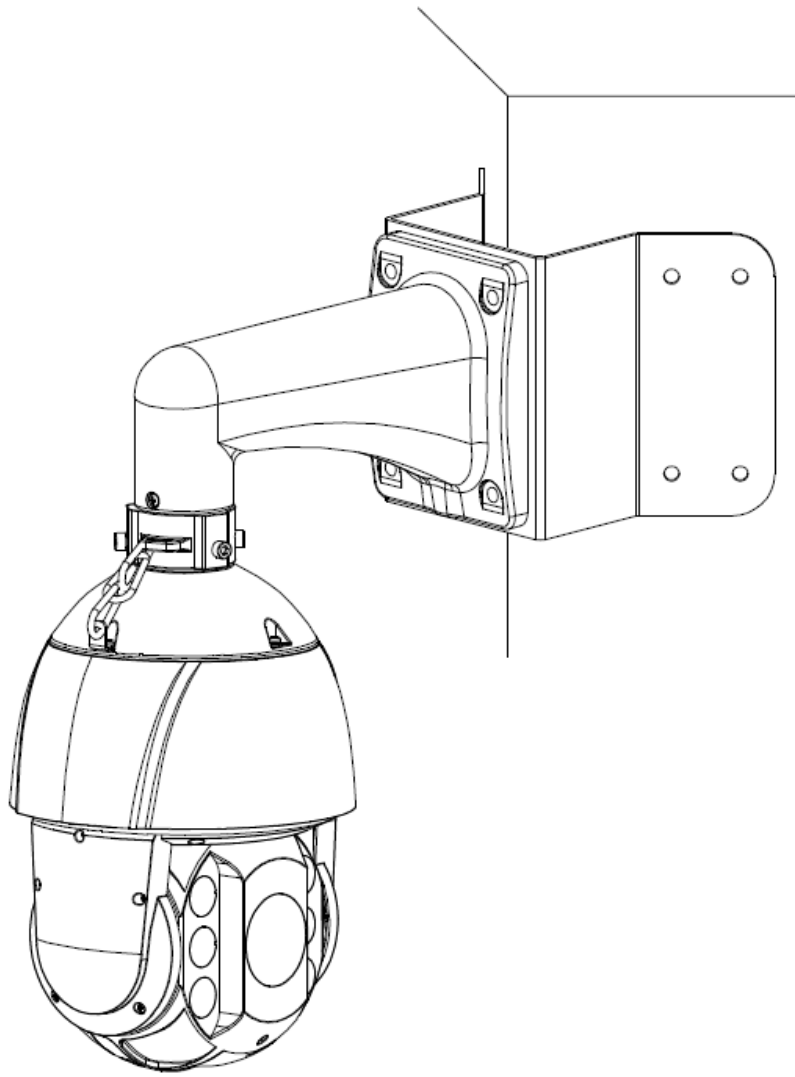

Figure 5-3

6 POLE MOUNT BRACKET INSTALLATION

Pole mount bracket and its components are shown as below. See Figure 6-1.

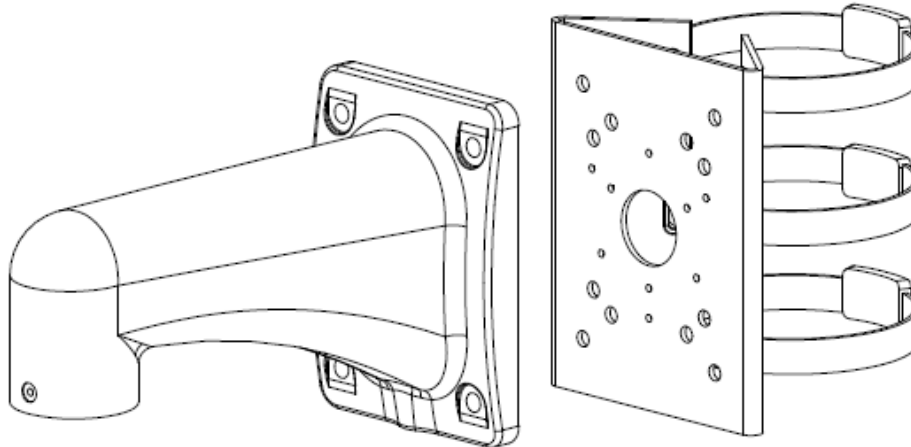

Figure 6-1

6.1 Installation

6.1.1 Installation Requirements

The pole mount speed dome can be installed in the hard construction wall in the indoor or outdoor environments.

Before the installation, please make sure:

The pole bracket can sustain the 8X weight of the speed dome.

The diameter of the pole structure shall comply with the installation dimension of the clamp. Default factory clamp is 5 inches for the column of $\phi 80-130\text{mm}$. It can work with the pole installation bracket. You can adjust the diameter and the value (clamp specification) is : $\phi 59-82\text{mm}$ 、 $\phi 84-108\text{mm}$ 、 $\phi 80-130\text{mm}$ 、 $\phi 130-152\text{mm}$ 、 $\phi 155-178\text{mm}$ 、 $\phi 180-203\text{mm}$ 、 $\phi 194-216\text{mm}$.

For special dimensions, please contact us for more information.

6.1.2 Installation Steps

Step 1

Please refer to Figure 6-2 to install clamp and pole bracket.

Pull the cable out of the pole accessories and then use clamp to fix the pole accessories to the pole. Finally, you can use glass cement to the output hole to secure waterproof.

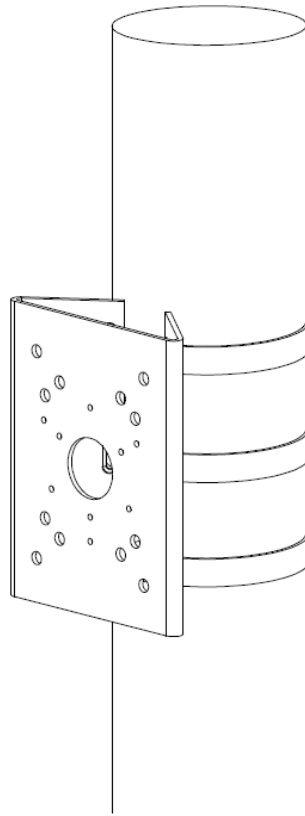

Figure 6-2

Note :

After the installation, please make sure the clamp is firmly secure in case it may result in clamp broken.

Step 2

Please refer to chapter 1.6 for detailed information about speed dome installation. See Figure 6-3.

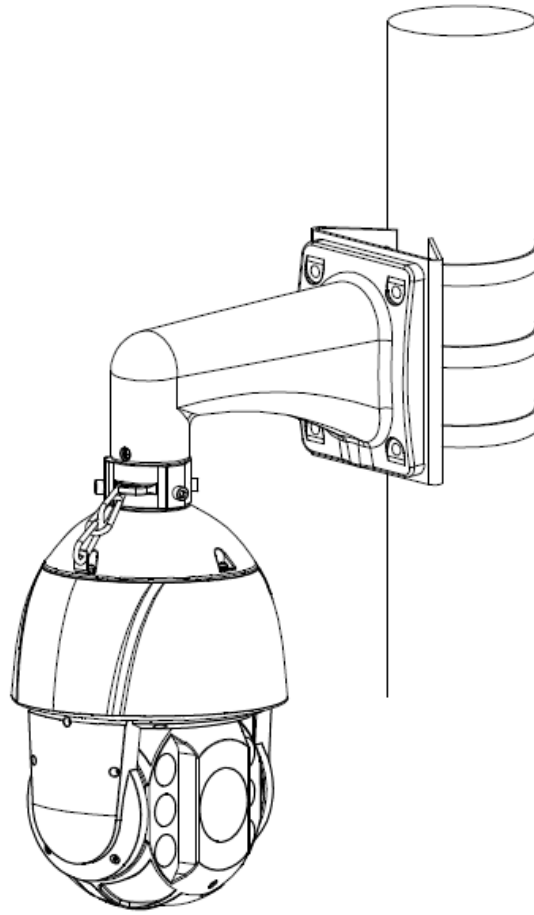

Figure 6-3

7 APPENDIX I LIGHTNING PROOF AND SURGE PROTECTION

This series speed dome adopts TVS lightning protection technology. It can effectively prevent damages from various pulse signals below 6000V, such as sudden lightning and surge. While maintaining your local electrical safety code, you still need to take necessary precaution measures when installing the speed dome in the outdoor environment.

- The distance between the signal transmission cable and high-voltage device (or high-voltage cable) shall be at least 50 meters.
- Outdoor cable layout shall go under the penthouse if possible.
- For vast land, please use sealing steel tube under the land to implement cable layout and connects one point to the earth. Open floor cable layout is forbidden.
- In area of strong thunderstorm hit or near high sensitive voltage (such as near high-voltage transformer substation), you need to install additional high-power thunder protection device or lightning rod.
- The thunder protection and earth of the outdoor device and cable shall be considered in the building whole thunder protection and conform to your local national or industry standard.
- System shall adopt equal-potential wiring. The earth device shall meet anti-jamming and at the same time conforms to your local electrical safety code. The earth device shall not short circuit to N (neutral) line of high voltage power grid or mixed with other wires. When connect the system to the earth alone, the earth resistance shall not be more than 4Ω and earth cable cross-sectional area shall be below 25 mm^2 . See Figure 7-1.

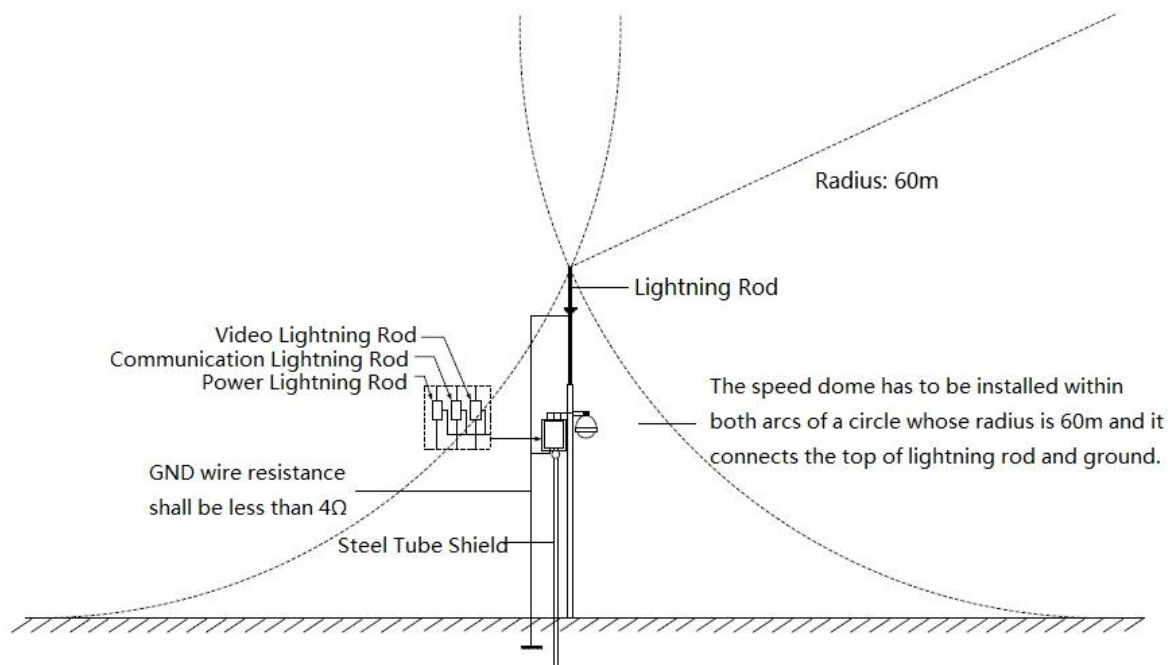

Figure 7-1

8 APPENDIX II ABOUT RS485 BUS

8.1 RS485 Bus Main Feature

RS485 is semi duplex communication cable of impedance 120Ω. Its max load amount is 32 effective loads (including main control device and devices to be charged).

8.2 RS485 Bus Transmission Distance

When we take 0.56mm (24AWG) twisted-pair as communication cable, the max transmission distance (theoretically) are listed below (according to different baud rates).

| Baud Rate | Max Distance |
|-----------|--------------|
| 2400 BPS | 1800M |
| 4800 BPS | 1200M |
| 9600 BPS | 800M |

In the following situations, the max transmission distance shall become shorter accordingly:

- The communication cable is a little bit thin;
- The surrounding environment has strong electromagnetic interference;
- There are too much devices connected to the RS485 bus;

And vice versa, the max transmission distance shall become longer.

8.3 The Problem in Practical Use

In practical usage, we usually adopt star type connection. The terminal resistance shall connect to the furthest two devices (Such as device 1# and device 15# in Figure 8-1). But this connection way does not conform to RS485 Bus standard. When the distances between devices are too long, the signal reflection occurs and anti-jamming decreases, thus the signal reliability becomes very low. You can see speed dome is not under control or speed dome is running automatically and can not stop.

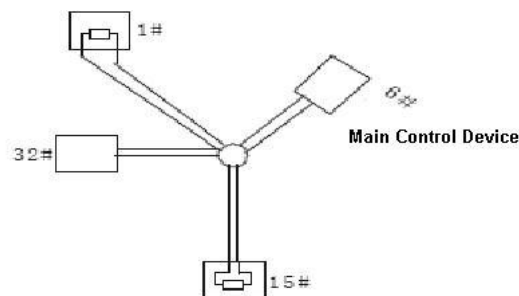

Figure 8-1

In this situation, we recommend RS485 distributor. This device can turn star type connection into the connection that conforms to RS485 bus industry standard, which can avoid the above mentioned problems and enhance communication reliability. See Figure 8-2.

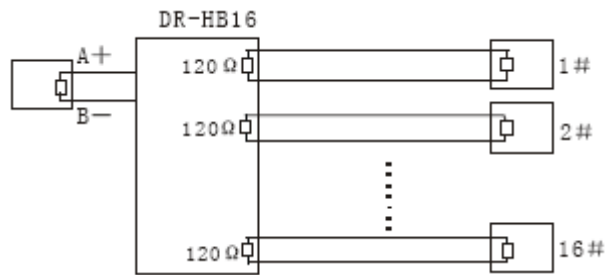

Figure 8-2

8.4 RS485 Bus FAQ

| Phenomenon | Possible Reasons | Solution |
|---|---|--|
| Speed dome can run self-diagnosis but I can not control it. | <ul style="list-style-type: none"> ● Host address(baud rate) and speed dome address(baud rate) are not match; ● Positive and negative end of RS485 Bus are misconnected; ● Connection cable is loose; ● RS485 Bus connection are cut off; | <ul style="list-style-type: none"> ● Modify host or speed dome setup ; ● Switch RS485 positive end and negative end; ● Fix connection cable firmly; ● Replace RS485 Bus. |
| I can control the speed dome but is not smooth | <ul style="list-style-type: none"> ● RS485 Bus connection are not good; ● One RS485 bus is off; ● The distance between host and speed dome is too far; ● Parallel connected too much speed domes. | <ul style="list-style-type: none"> ● Connect RS 485 Bus again; ● Replace RS485 Bus; ● Add terminal matching resistance; ● Add RS485 distributor. |

9 APPENDIX III THE RELATIONSHIP BETWEEN THE 24V AC CABLE DIAMETER AND THE TRANSMISSION DISTANCE

It is the recommended transmission distance when the cable diameter is fixed and the 24V AC power consumption is below 10%. For the AC device, the max permission voltage power consumption is 10%. For example, when a device of rated power 20W installed from the transformer 141 inches (42m), then the min cable diameter is 0.8000mm.

| Feet (m) w | mm | | | |
|---------------|--------------------|--------------------|---------------------|---------------------|
| | 0.8000 | 1.000 | 1.250 | 2.000 |
| 5 | 488.52 (148.90) | 763.31 (232.66) | 1192.67 (363.53) | 3053.25 (930.63) |
| 10 | 244.26 (74.45) | 381.66 (116.33) | 596.34 (181.76) | 1526.62 (465.31) |
| 15 | 162.84 (49.63) | 254.44 (77.55) | 397.56 (121.18) | 1017.75 (310.21) |
| 20 | 122.13 (37.23) | 190.83 (58.16) | 298.17 (90.88) | 763.31 (232.66) |
| 25 | 97.70 (29.78) | 152.66 (46.53) | 238.53 (72.71) | 610.65 (186.13) |
| 30 | 81.42 (24.82) | 127.22 (38.78) | 198.78 (60.59) | 508.87 (155.10) |
| 35 | 69.79 (21.27) | 109.04 (33.24) | 170.38 (51.93) | 436.18 (132.95) |
| 40 | 61.06 (18.61) | 95.41 (29.08) | 149.08 (45.44) | 381.66 (116.33) |
| 45 | 54.28 (16.54) | 84.81 (25.85) | 132.52 (40.39) | 339.25 (103.40) |
| 50 | 48.85 (14.89) | 76.33 (23.27) | 119.27 (36.35) | 305.32 (93.06) |
| 55 | 44.41 (13.54) | 69.39 (21.15) | 108.42 (33.05) | 277.57 (84.60) |
| 60 | 40.71 (12.41) | 63.61 (19.39) | 99.39 (30.29) | 254.44 (77.55) |
| 65 | 37.58 (11.45) | 58.72 (17.90) | 91.74 (27.96) | 234.87 (71.59) |
| 70 | 34.89 (10.64) | 54.52 (16.62) | 85.19 (25.97) | 218.09 (66.47) |
| 75 | 32.57 (9.93) | 50.89 (15.51) | 79.51 (24.24) | 203.55 (62.04) |
| 80 | 30.53 (9.31) | 47.71 (14.54) | 74.54 (22.72) | 190.83 (58.16) |
| 85 | 28.74 (8.76) | 44.90 (13.69) | 70.16 (21.38) | 179.60 (54.74) |
| 90 | 27.14 (8.27) | 42.41 (12.93) | 66.26 (20.20) | 169.62 (51.70) |
| 95 | 25.71 (7.84) | 40.17 (12.25) | 62.77 (19.13) | 160.70 (48.98) |

| Feet (m) w | mm | 0.8000 | 1.000 | 1.250 | 2.000 |
|---------------|----|--------------|---------------|---------------|----------------|
| 100 | | 24.43 (7.45) | 38.17 (11.63) | 59.63 (18.18) | 152.66 (46.53) |

10 APPENDIX IV THE RELATIONSHIP BETWEEN THE 12V DC CABLE DIAMETER AND THE TRANSMISSION DISTANCE

It is the recommended transmission distance when the cable diameter is fixed and the 12V DC power consumption is below 10%. For the DC device, the max permission voltage power consumption is 10%. The cables used in the following sheet are all copper wires. (the resistivity of copper is $\rho = 0.0175\Omega * \text{mm}^2/\text{m}$)

| Feet (m) w | mm | | | |
|---------------|-------------------|-------------------|-------------------|--------------------|
| | 0.8000 | 1.000 | 1.250 | 2.000 |
| 5 | 122.13 (37.23) | 190.83 (58.16) | 298.17 (90.88) | 763.31 (232.66) |
| 10 | 61.06 (18.61) | 95.41 (29.08) | 149.08 (45.44) | 381.66 (116.33) |
| 15 | 40.71 (12.41) | 63.61 (19.39) | 99.39 (30.29) | 254.44 (77.55) |
| 20 | 30.53 (9.31) | 47.71 (14.54) | 74.54 (22.72) | 190.83 (58.16) |
| 25 | 24.43 (7.45) | 38.17 (11.63) | 59.63 (18.18) | 152.66 (46.53) |
| 30 | 20.35 (6.20) | 31.80 (9.69) | 49.69 (15.15) | 127.22 (38.78) |
| 35 | 17.45 (5.32) | 27.26 (8.31) | 42.60 (12.98) | 109.04 (33.24) |
| 40 | 15.27 (4.65) | 23.85 (7.27) | 37.27 (11.36) | 95.41 (29.08) |
| 45 | 13.57 (4.14) | 21.20 (6.46) | 33.13 (10.10) | 84.81 (28.85) |
| 50 | 12.21 (3.72) | 19.08 (5.82) | 29.82 (9.09) | 76.33 (23.27) |
| 55 | 11.10 (3.38) | 17.35 (5.29) | 27.11 (8.26) | 69.39 (21.15) |
| 60 | 10.18 (3.10) | 15.90 (4.85) | 24.85 (7.57) | 63.61 (19.39) |
| 65 | 9.39 (2.86) | 14.68 (4.47) | 22.94 (6.99) | 58.72 (17.90) |
| 70 | 8.72 (2.66) | 13.63 (4.15) | 21.30 (6.49) | 54.52 (16.62) |
| 75 | 8.14 (2.48) | 12.72 (3.88) | 19.88 (6.06) | 50.89 (15.51) |
| 80 | 7.63 (2.33) | 11.93 (3.64) | 18.64 (5.68) | 47.71 (14.54) |
| 85 | 7.18 (2.19) | 11.23 (3.42) | 17.54 (5.35) | 44.90 (13.69) |
| 90 | 6.78 (2.07) | 10.60 (3.23) | 16.56 (5.05) | 42.41 (12.93) |
| 95 | 6.43 (1.96) | 10.04 (3.06) | 15.69 (4.78) | 40.17 (12.25) |

| Feet (m) w | mm | 0.8000 | 1.000 | 1.250 | 2.000 |
|---------------|----|-------------|-------------|--------------|---------------|
| 100 | | 6.11 (1.86) | 9.54 (2.91) | 14.91 (4.54) | 38.17 (11.63) |

11 APPENDIX IV WIRE GAUGE REFERENCE SHEET

| Metric bare wire diameter (mm) | AWG | SWG | Bare wire cross section (mm ²) |
|--------------------------------|-----|-----|--|
| 0.050 | 43 | 47 | 0.00196 |
| 0.060 | 42 | 46 | 0.00283 |
| 0.070 | 41 | 45 | 0.00385 |
| 0.080 | 40 | 44 | 0.00503 |
| 0.090 | 39 | 43 | 0.00636 |
| 0.100 | 38 | 42 | 0.00785 |
| 0.110 | 37 | 41 | 0.00950 |
| 0.130 | 36 | 39 | 0.01327 |
| 0.140 | 35 | | 0.01539 |
| 0.160 | 34 | 37 | 0.02011 |
| 0.180 | 33 | | 0.02545 |
| 0.200 | 32 | 35 | 0.03142 |
| 0.230 | 31 | | 0.04115 |
| 0.250 | 30 | 33 | 0.04909 |
| 0.290 | 29 | 31 | 0.06605 |
| 0.330 | 28 | 30 | 0.08553 |
| 0.350 | 27 | 29 | 0.09621 |
| 0.400 | 26 | 28 | 0.1257 |
| 0.450 | 25 | | 0.1602 |
| 0.560 | 24 | 24 | 0.2463 |
| 0.600 | 23 | 23 | 0.2827 |
| 0.710 | 22 | 22 | 0.3958 |
| 0.750 | 21 | | 0.4417 |
| 0.800 | 20 | 21 | 0.5027 |
| 0.900 | 19 | 20 | 0.6362 |
| 1.000 | 18 | 19 | 0.7854 |
| 1.250 | 16 | 18 | 1.2266 |
| 1.500 | 15 | | 1.7663 |
| 2.000 | 12 | 14 | 3.1420 |
| 2.500 | | | 4.9080 |
| 3.000 | | | 7.0683 |

Note

- **This manual is for reference only. Slight difference may be found in the user interface.**
- **All the designs and software here are subject to change without prior written notice.**
- **All trademarks and registered trademarks are the properties of their respective owners.**
- **If there is any uncertainty or controversy, please refer to the final explanation of us.**
- **Please visit our website or contact your local service engineer for more information.**