Intelligent Speed Dome Installation Manual

Version 1.1.1

Table of Contents

1	INTELLIGENT SPEED DOME INSTALLATION.....	1
1.1	Installation Environments	1
1.2	Check installation space and installation location intension	1
1.3	About cable.....	1
1.4	Please keep all package material well for future use.....	1
2	SETUP BEFORE INSTALLATION.....	3
2.1	Check Accessories.....	3
2.2	Open Device.....	3
2.3	Initial Setup.....	3
2.4	Dial Switch Setup (Analog Speed Dome).....	4
2.4.1	Dial Switch Setup for Intelligent Speed Dome.....	4
2.4.2	Baud Rate and Parity Setup.....	5
2.4.3	Speed Dome Address Setup.....	5
2.4.4	Terminal Matching Resistance Setup	6
2.5	Dial Switch Setup (HDCVI Speed Dome).....	7
2.5.1	Dial Switch Setup for Intelligent Speed Dome.....	7
2.5.2	Baud Rate and Parity Setup.....	8
2.5.3	Speed Dome Address Setup.....	8
2.5.4	Terminal Matching Resistance Setup	9
3	CEILING MOUNT.....	10

3.1	Installation Components	10
3.2	Ceiling Mount Installation Steps	10
3.2.1	Installation Environments.....	10
3.2.2	Installation Steps.....	10
3.2.3	Cable Connection	12
4	WALL MOUNT BRACKET INSTALLATION.....	13
4.1	Component Installation	13
4.2	Wall Mount Installation Steps	13
4.2.1	Installation Environments.....	13
4.2.2	Installation Steps.....	13
5	IN-CEILING MOUNT BRACKET INSTALLATION	16
5.1	Component Installation	16
5.2	Installation.....	16
5.2.1	Installation Requirements	16
5.2.2	Installation Steps.....	16
6	APPENDIX I THUNDER PROOF AND SURGE PROTECTION	19
7	APPENDIX II ABOUT RS485 BUS	20
7.1	RS485 Bus Main Feature	20
7.2	RS485 Bus Transmission Distance	20
7.3	The Problem in Practical Use	20
7.4	RS485 Bus FAQ	21

8	APPENDIX III THE 24V AC WIRE GAUGE AND TRANSMISSION DISTANCE RELATIONSHIP SHEET	22
9	APPENDIX IV 12V AC WIRE GAUGE AND TRANSMISSION DISTANCE RELATIONSHIP SHEET	23
10	APPENDIX V WIRE GAUGE REFERENCE SHEET	24

Welcome

Thank you for purchasing our speed dome!

Please read the following safeguards and warnings carefully before you install or use the product!

Important Safeguards and Warnings

Safety Measures

1. Qualified Engineer Needed

- The installation engineer or maintenance engineer shall have corresponding CCTV system installation certificate or maintenance qualification certificate.
- The installation engineer or maintenance engineer shall have qualification certificate for work at height.
- The installation engineer or maintenance engineer shall have the basic knowledge and operation technique for low-voltage cable layout and low-voltage electronic cable connection.
- Please read the installation manual carefully and keep it well for future reference,
- We are not liable for any problems caused by unauthorized modifications or attempted repair.

2. Lifting Appliance Requirement

- Please select the proper speed dome installation mode and use the lifting appliances at the safety environment.
- The lifting appliances shall have the enough capacity to reach the installation height.
- The lifting appliances shall have safe performance.

The precaution measures include two types: Warning and Note.

- **Warning:** It is to alert you there is an optional risk of death or series injury!
- **Note:** It is to alert you there is an optional risk of damage or property loss!

Warning

1. All installation and operation here should conform to your local electrical safety codes. We assume no liability or responsibility for all the fires or electrical shock caused by improper handling or installation.
2. Be sure to use all the accessories (such as power adapter) recommended by manufacturer.
3. Do not connect several speed domes to one power adapter. It may result in overheat or fire if it exceeds the rated load.
4. Before you connect the cable, install or uninstall, or begin the daily maintenance work, please turn off the power and unplug the power cable.
5. Please make sure the produce is secure firmly on the wall or the ceiling.
6. Please turn off the power and unplug the power cable, If there is any smoke, disgusting smell, or noise. Please contact your local retailer or customer service centre for help.

-
7. All the examination and repair work should be done by the qualified service engineers. We are not liable for any problems caused by unauthorized modifications or attempted repair.

Note

1. Safety Transportation

- Heavy stress, violent vibration or water splash are not allowed during transportation, storage and installation.
- This series product must use split type package during the transportation.
- We are not liable for any damage or problem resulting from the integrated package during the transportation.

2. When device is malfunction

Shut down the device and disconnect the power cable immediately if there is smoke, abnormal smell or abnormal function. Please contact your local retailer ASAP.

3. Do not try to dismantle or modify the device

- There is risk of personal injury or device damage resulting from opening the shell.
- Please contact your local retailer if there is internal setup or maintenance requirement.
- We are not liable for any problems caused by unauthorized modifications or attempted repair.

4. Do not allow other object falling into the device

- Please make sure there is no metal or inflammable, explosive substance in the speed dome.
- The above mentioned objects in the device may result in fire, short-circuit or damage.
- Please shut down the device and disconnect the power cable if there is water or liquid falling into the camera. Please contact your local retailer ASAP.
- Please pay attention to the camera. Avoid the sea water or rain to erode the camera.

5. Handle carefully

Do not allow this series product fall down to the ground.
Avoid heavy vibration.

6. Installation Environment Requirement

- This series speed dome should be installed in a cool, dry place away from direct sunlight, inflammable, explosive substances and etc.
- This series product shall be away from the strong electromagnetism radiant, please keep it away from wireless power, TV transmitter, transformer and etc.

7. Daily Maintenance

- Please use the soft cloth to clean dust on the shell, or you can use soft cloth with cleaning liquid to clean the shell and then use soft cloth to make it dry.

-
- Do not use gasoline, dope thinner or other chemical material to clean the shell. It may result in shell transfiguration or paint flake.
 - Do not allow the plastic or rubber material to touch the shell for a long time. It may result in paint flake.

1 INTELLIGENT SPEED DOME INSTALLATION

1.1 Installation Environments

Basic Requirement

- All installation and operation here should conform to your local electrical safety codes.
- Before installation, please open the package and check all the components are included. Please make sure the speed dome installation environment and installation mode can meet your requirement. If there is special requirement, please contact your local retailer for more information.
- We assume no liability or responsibility for all the fires or electrical shock caused by improper handling or installation.

1.2 Check installation space and installation location intension

Please make sure the installation environment has enough space to install the speed dome and its corresponding bracket.

Please make sure the ceiling, wall and the bracket can support the speed dome and its corresponding installation component. It shall sustain the 8X weight of the speed dome.

1.3 About cable

Please select the cable according to your transmission distance.

The minimum video coaxial-cable requirement is:

- 75 ohm.
- Full cable with copper conductor
- 95% knitted copper shield
- Please refer to Appendix 2 for RS485 communication cable information.

International Model	Max Transmission Distance (Ft\M)
RG59/U	750Ft (229M)
RG6/U	1,000Ft (305M)
RG11/U	1,500Ft (457M)

Note: The above can be applied to analog speed dome and network speed dome

International Mode	Max Transmission Distance (M\Ft)
SYV-75-3	720P (25fps\30fps): 500M/1640Ft
	720P (50fps\60fps): 300M/984Ft
	1080P (25fps\30fps): 300M/984Ft

Note: The above can be applied to HDCVI speed dome

Select eclectic wire according to your transmission distance:

- For 24V AC series product, please refer to Appendix 3.
- For 12V DC series product, please refer to Appendix 4.

1.4 Please keep all package material well for future use

Please keep speed dome package material well in case you need to send it back to your local retailer or manufacturer for maintenance work.

Non-original package material may result in device damage during the transportation.

2 SETUP BEFORE INSTALLATION

2.1 Check Accessories

Before the installation, please check the accessories one by one according to the packing list. Please make sure all the components listed are included.

2.2 Open Device

This section is for intelligent analog speed dome, intelligent network speed dome, and intelligent tracking speed dome.

Remove the package and then take out the device. Open the transparent cover and take out the packing material EPE around the speed dome drive. Please remove the paster from the pedestal. See Figure 2-1.

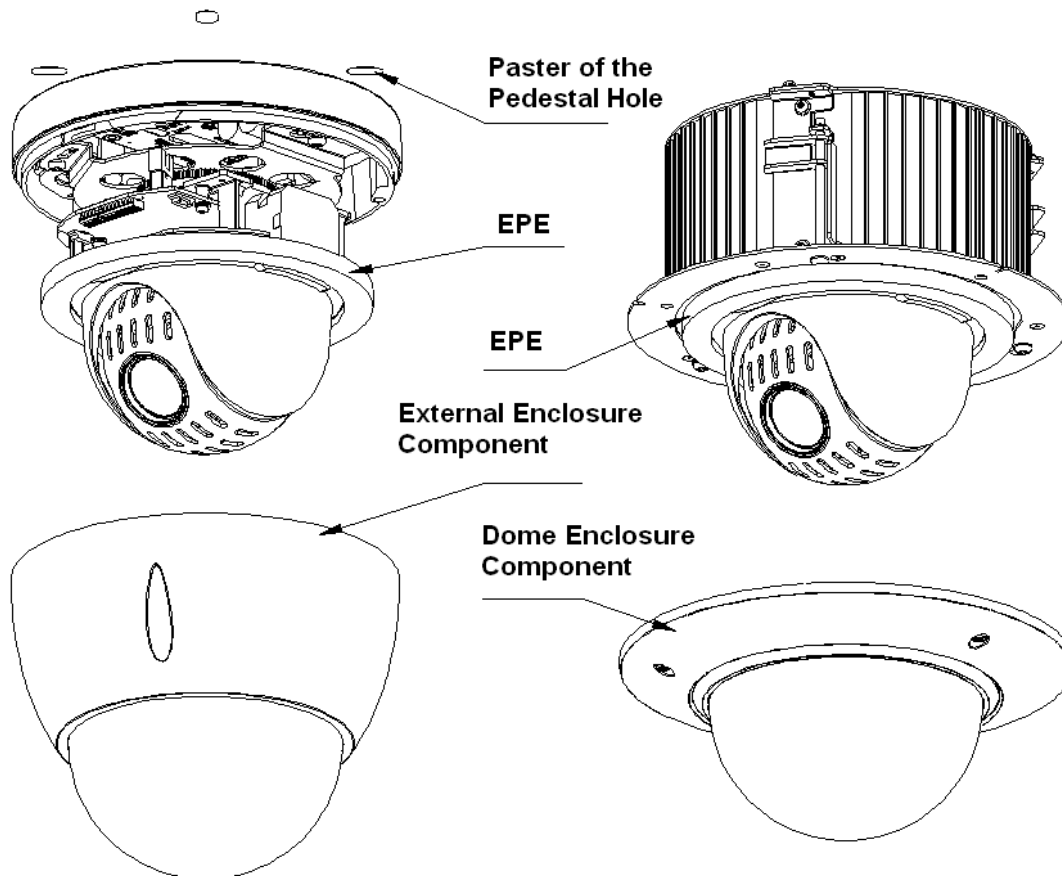

Figure 2-1

2.3 Initial Setup

The default setup is:

- Address: 1
- Baud rate: 9600
- Parity: None
- 120Ω resistance: OFF

2.4 Dial Switch Setup (Analog Speed Dome)

The following operation is based on the ceiling mount speed dome. Here we are going to set speed dome address, baud rate and etc. There are two dial switches on the PTZ for you to set address, baud rate and etc. See Figure 2-2.

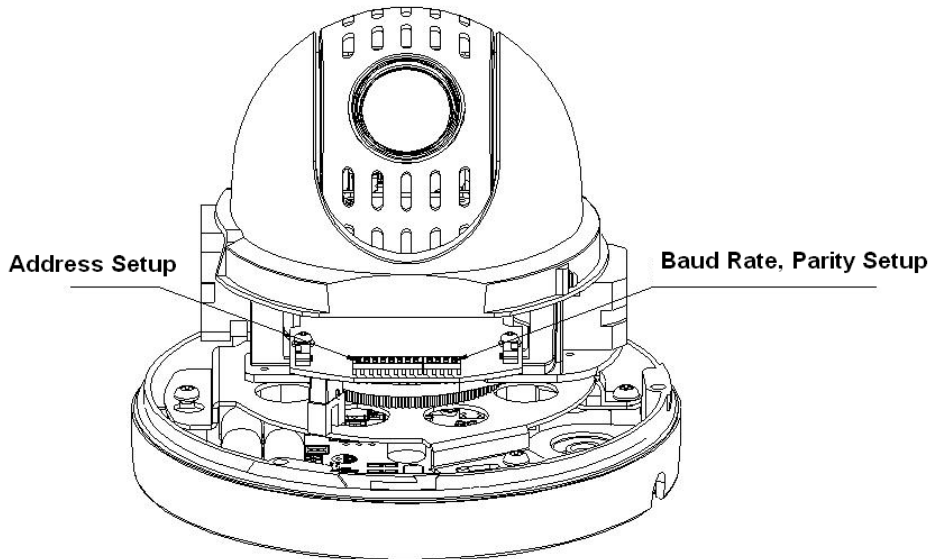

Figure 2-2

2.4.1 Dial Switch Setup for Intelligent Speed Dome

Before you control speed dome, please set the speed dome address, baud rate, parity.

Otherwise, you cannot control the device! See Figure 2-3.

Open speed dome transparent enclosure, you can view the dial switch buttons on the PTZ main board. You can follow the steps listed below to set the speed dome address, baud rate, and parity. **Please note you need to restart the device to activate the new setup!**

For wall mount speed dome, you need to take out the packing material EPE, set the dial switch buttons and then put it back to the transparent enclosure module.

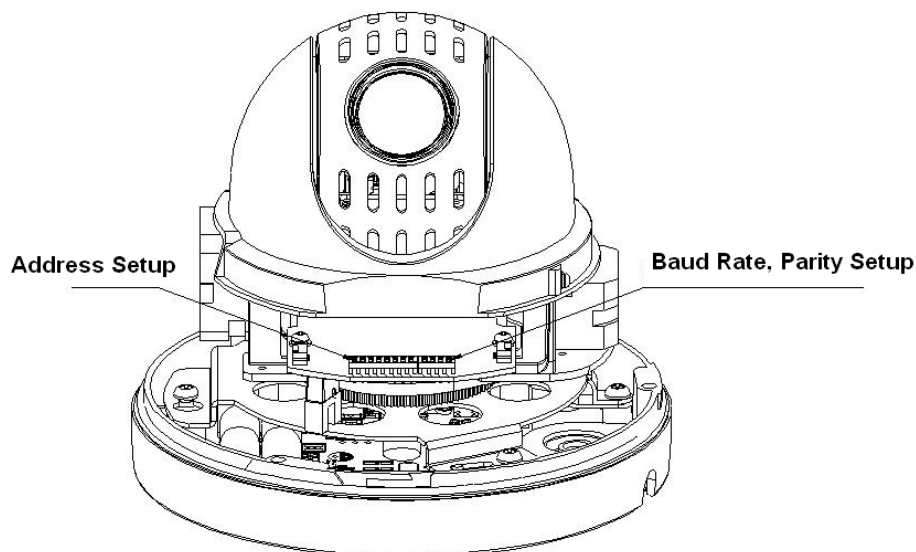

Figure 2-3

There are two dial switch buttons on the PTZ. You can use them to set speed dome address, baud rate, and parity respectively. It is 1 when you set the button as ON. 1 is the lowest bit for address setup dial, 8 is the highest bit; 1 is the lowest bit for the baud rate and parity setup dial, 4 is the highest bit.

Please note the intelligent speed dome self-adapt PELCO-D. PELCO-P and industrial standard protocol, the control protocol doesn't have to be set via dial.

2.4.2 Baud Rate and Parity Setup

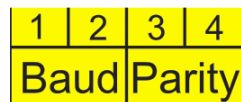

Figure 2-4

For the dial switch button from 1 to 4, 1 and 2 bit is used to set baud rate, 3 and 4 bit is used to set parity. Please refer to the following figure for detailed information.

Please refer to the baud rate sheet for detailed information.

1	2	Baud Rate
OFF	OFF	9600bps
ON	OFF	4800bps
OFF	ON	2400bps
ON	ON	1200bps

Please refer to the parity setup sheet for detailed information.

3	4	Parity
OFF	OFF	NONE
ON	OFF	EVEN
OFF	ON	ODD
ON	ON	NONE

2.4.3 Speed Dome Address Setup

The address interface is shown as in Figure 2-5.

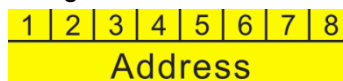

Figure 2-5

The encode mode adopts binary system. 1 to 8 is valid bit. The highest address bit is 255. You can refer to the following sheet for more information.

Address	1	2	3	4	5	6	7	8
1	OFF	OFF	OFF	OFF	OFF	OFF	OFF	OFF
1	ON	OFF	OFF	OFF	OFF	OFF	OFF	OFF
2	OFF	ON	OFF	OFF	OFF	OFF	OFF	OFF

3	ON	ON	OFF	OFF	OFF	OFF	OFF	OFF
4	OFF	OFF	ON	OFF	OFF	OFF	OFF	OFF
5	ON	OFF	ON	OFF	OFF	OFF	OFF	OFF
6	OFF	ON	ON	OFF	OFF	OFF	OFF	OFF
7	ON	ON	ON	OFF	OFF	OFF	OFF	OFF
8	OFF	OFF	OFF	ON	OFF	OFF	OFF	OFF
.....							
254	OFF	ON	ON	ON	ON	ON	ON	ON
255	ON	ON	ON	ON	ON	ON	ON	ON

2.4.4 Terminal Matching Resistance Setup

There is terminal resistance 120Ω on the main board. There are two modes: See

Figure 2-6.

	1-2	2-3
120Ω	ON	OFF

Figure 2-6

The factory default setup is shown as in Figure 2-7. Right now, the jumper (Connection board) is on the pin 2 and pin 3. The 120Ω resistance does not connect to the device.

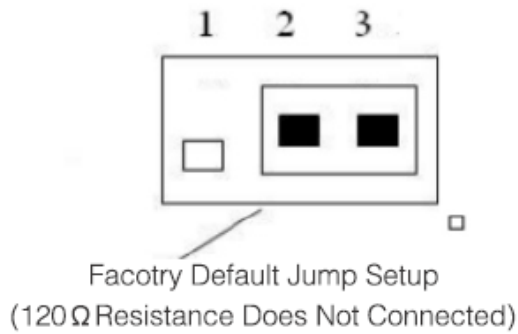

Figure 2-7

If you want to connect the 120Ω resistance, please remove the jumper from the pin 2 and pin 3 and connect to pin 1 and pin 2. Now the 120Ω is connected to the circuit. See Figure 2-8.

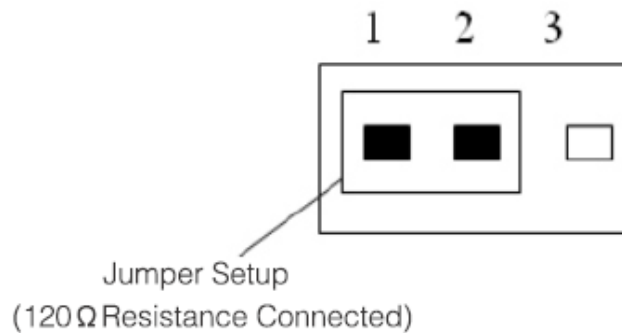

Figure 2-8

2.5 Dial Switch Setup (HDCVI Speed Dome)

The following operation is based on the ceiling mount speed dome. Here we are going to set speed dome address, baud rate and etc. There are two dial switches on the PTZ for you to set address, baud rate and etc. See Figure 2-9.

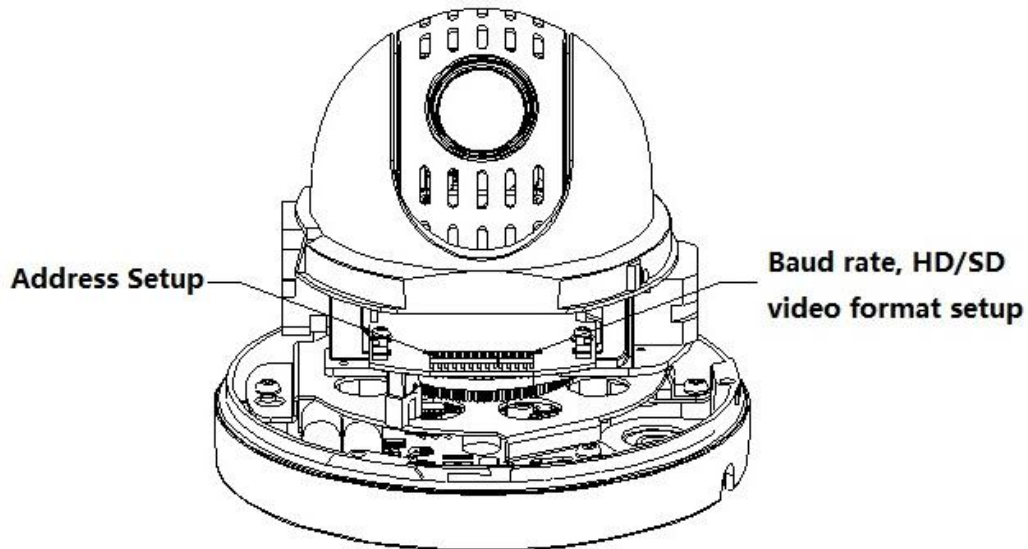

Figure 2-9

2.5.1 Dial Switch Setup for Intelligent Speed Dome

Before you control speed dome, please set the speed dome address, baud rate and HD/SD video format. Otherwise, you cannot control the device! See Figure 2-10.

Open speed dome transparent enclosure, you can view the dial switch buttons on the PTZ main board. You can follow the steps listed below to set the speed dome address, baud rate, and HD/SD video format setup. **Please note you need to restart the device to activate the new setup!**

For wall mount speed dome, you need to take out the packing material EPE, set the dial switch buttons and then put it back to the transparent enclosure module.

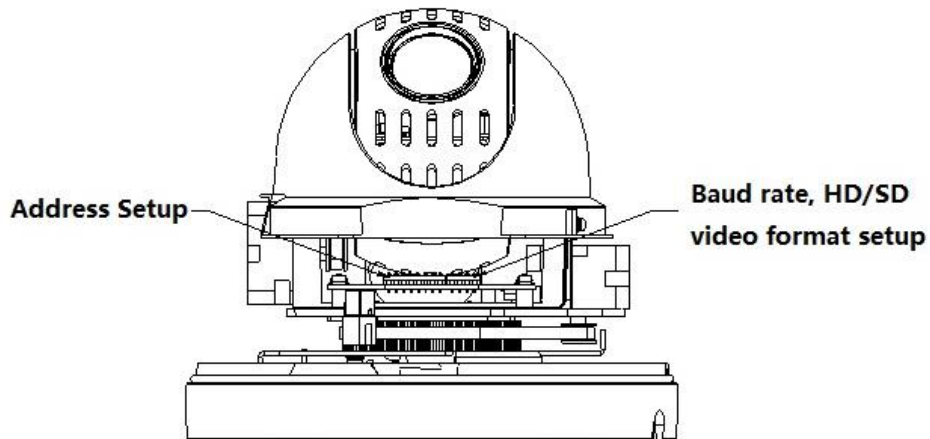

Figure 2-10

There are two dial switch buttons on the PTZ. You can use them to set speed dome address, baud rate and HD/SD video format respectively. It is 1 when you set the button as ON. 1 is the lowest bit for address setup dial, 8 is the highest bit; 1 is the lowest bit for the baud rate and HD/SD video format setup dial, 4 is the highest bit.

Please note the intelligent speed dome self-adapt PELCO-D. PELCO-P and industrial standard protocol, the control protocol doesn't have to be set via dial.

2.5.2 Baud Rate and Parity Setup

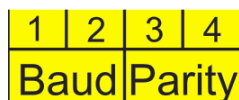

Figure 2-11

For the dial switch button from 1 to 4, 1 and 2 bit is used to set baud rate, 3 and 4 bit is used to set HD/SD video format. Please refer to the following figure for detailed information.

Please refer to the baud rate sheet for detailed information.

1	2	Baud Rate
OFF	OFF	9600bps
ON	OFF	4800bps
OFF	ON	2400bps
ON	ON	1200bps

Please refer to the HD/SD video format setup sheet for detailed information.

3	4	HD/SD video format
OFF	OFF	HD
ON	OFF	SD
OFF	ON	Self-adapt
ON	ON	HD

2.5.3 Speed Dome Address Setup

The address interface is shown as in Figure 2-5.

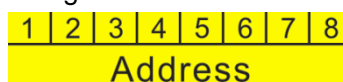

Figure 2-12

The encode mode adopts binary system. 1 to 8 is valid bit. The highest address bit is 255. You can refer to the following sheet for more information.

Address	1	2	3	4	5	6	7	8
1	OFF	OFF	OFF	OFF	OFF	OFF	OFF	OFF
1	ON	OFF	OFF	OFF	OFF	OFF	OFF	OFF
2	OFF	ON	OFF	OFF	OFF	OFF	OFF	OFF

3	ON	ON	OFF	OFF	OFF	OFF	OFF	OFF
4	OFF	OFF	ON	OFF	OFF	OFF	OFF	OFF
5	ON	OFF	ON	OFF	OFF	OFF	OFF	OFF
6	OFF	ON	ON	OFF	OFF	OFF	OFF	OFF
7	ON	ON	ON	OFF	OFF	OFF	OFF	OFF
8	OFF	OFF	OFF	ON	OFF	OFF	OFF	OFF
.....							
254	OFF	ON	ON	ON	ON	ON	ON	ON
255	ON	ON	ON	ON	ON	ON	ON	ON

2.5.4 Terminal Matching Resistance Setup

There is terminal resistance 120Ω on the main board. There are two modes: See Figure 2-13.

	1-2	2-3
120Ω	ON	OFF

Figure 2-13

The factory default setup is shown as in Figure 2-14. Right now, the jumper (Connection board) is on the pin 2 and pin 3. The 120Ω resistance does not connect to the device.

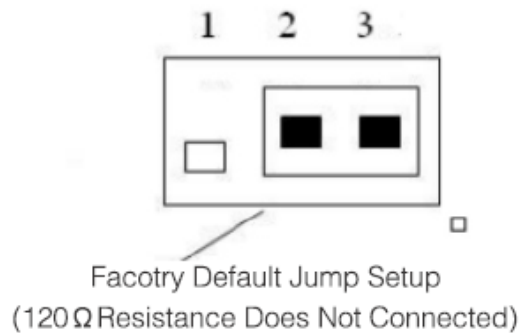

Figure 2-14

If you want to connect the 120Ω resistance, please remove the jumper from the pin 2 and pin 3 and connect to pin 1 and pin 2. Now the 120Ω is connected to the circuit. See Figure 2-15.

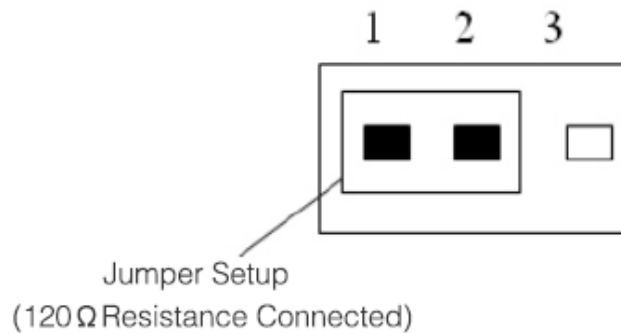

Figure 2-15

3 CEILING MOUNT

3.1 Installation Components

The ceiling mount installation component is shown as in Figure 3-1.

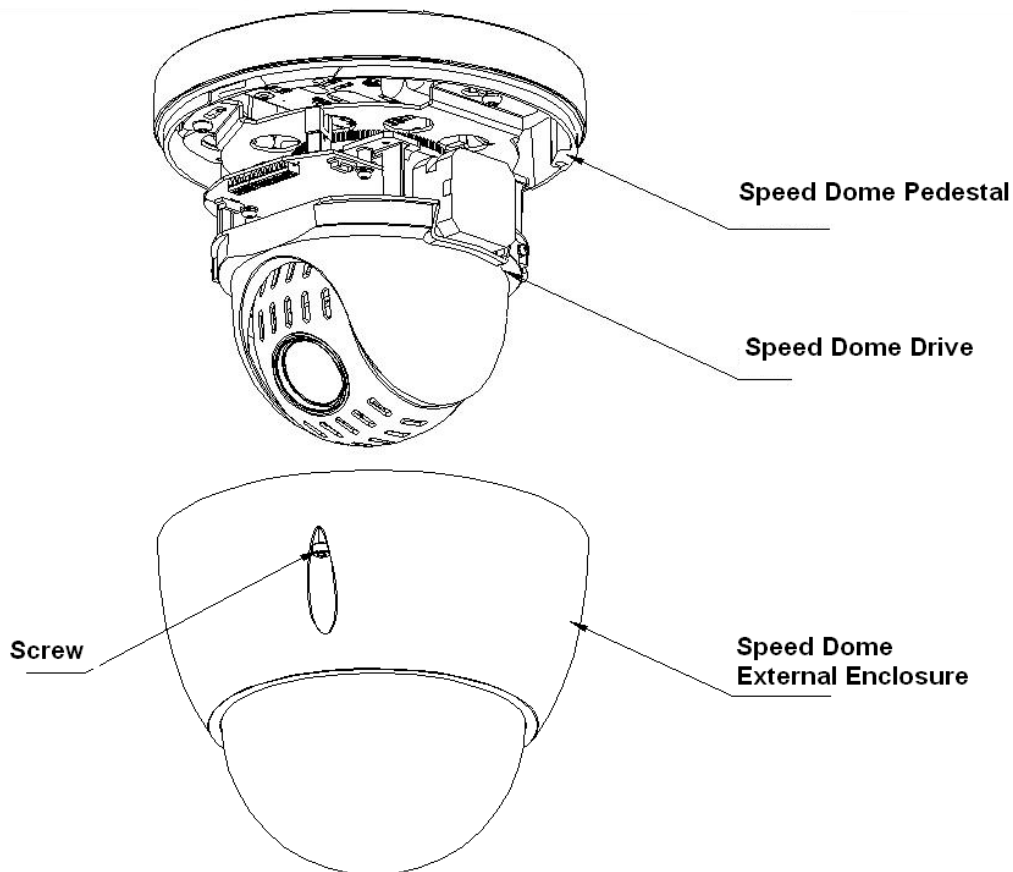

Figure 3-1

3.2 Ceiling Mount Installation Steps

3.2.1 Installation Environments

The ceiling mount speed dome can be installed in the hard construction wall in the indoor environments. Before the installation, please make sure:

- The wall is thick enough to install the expansion bolt.
- The ceiling can at least sustain the 8x weight of the speed dome, bracket and the accessories.

3.2.2 Installation Steps

- 1) The ceiling installation has two cable exit modes: One is to pull the cable through the side cable exit of the speed dome without dig holes on the ceiling. The other is to dig holes on the ceiling and pull the cable through the ceiling.
- 2) Confirm installation position and cable exit mode. Use the ceiling installation position map to dig holes on the ceiling and then put the four plastic expansion bolts firmly.

- 3) In Figure 3-2, pull the cable according to your cable exit mode. And then use four screws (working with insulated sleeve) to secure the pedestal of ceiling mount speed dome on the ceiling. Turn the screws to the plastic expansion bolts.

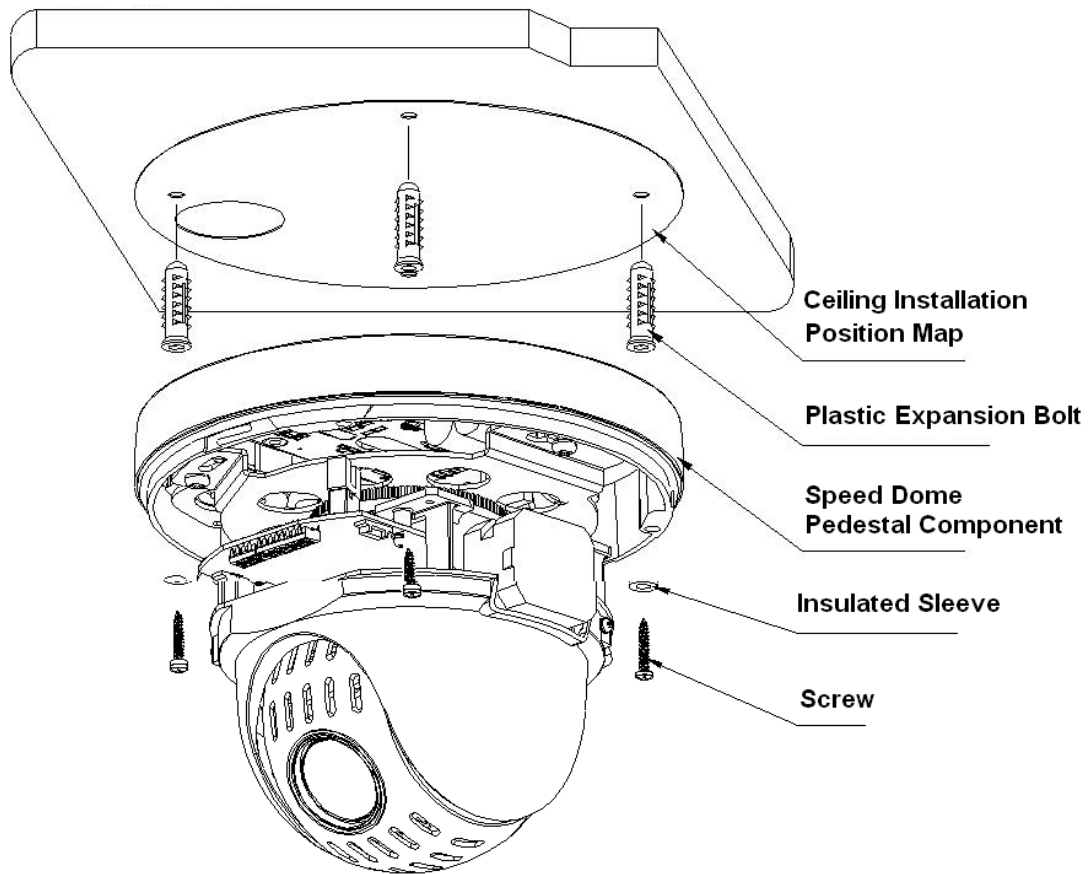

Figure 3-2

- 4) In Figure 3-3, line up the arrow symbol on the speed dome external enclosure to the bar symbol of the pedestal. Use three screws (provided) to secure the external enclosure on the pedestal and fix firmly.

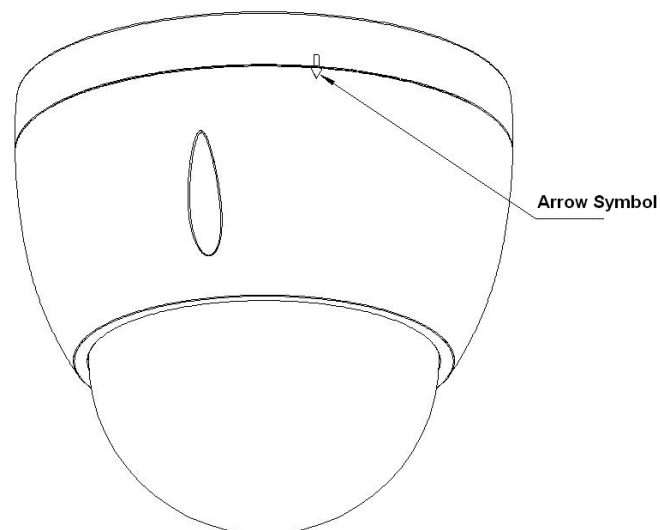

Figure 3-3

3.2.3 Cable Connection

The step listed below is for ceiling, in-ceiling or wall mount series product.

Please connect the power cable, video output cable, RS485 control cable, alarm input/output pin of the intelligent speed dome composite cable according to your actual requirements. Please use insulation tape to seal the cable connection ports to do proper waterproof work.

Note

The video port is covered the heat shrink tube of high shrinking ratio. After the video connection, please heat the tube to make sure the video port is damp proof and water proof.

4 WALL MOUNT BRACKET INSTALLATION

4.1 Component Installation

The wall mount bracket and outdoor speed dome is shown as in Figure 4-1.

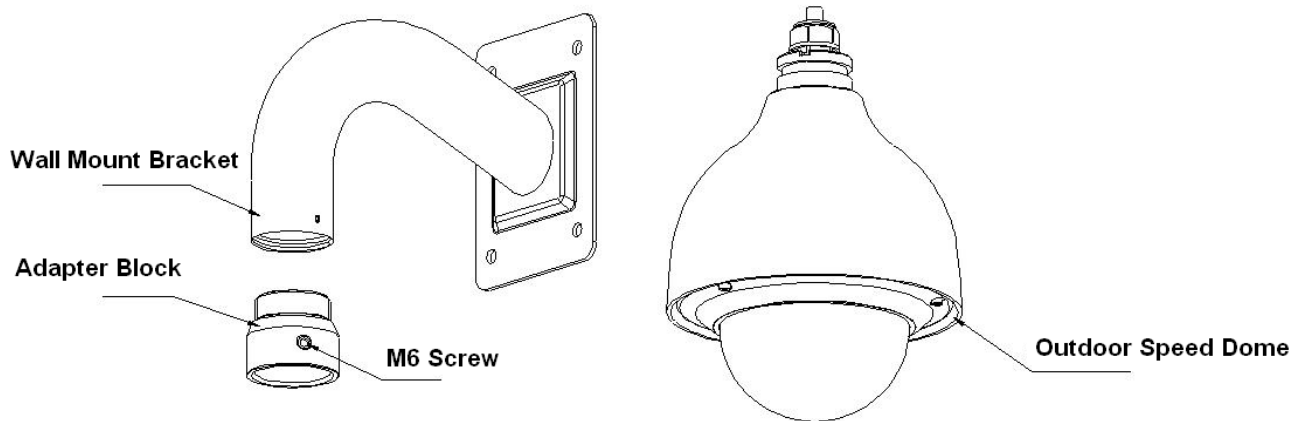

Figure 4-1

4.2 Wall Mount Installation Steps

4.2.1 Installation Environments

The wall mount speed dome can be installed in the hard construction wall in the indoor or outdoor environments. Before the installation, please make sure:

- The wall is thick enough to install the expansion bolt.
- The ceiling can at least sustain the 8x weight of the speed dome, bracket and the accessories.

4.2.2 Installation Steps

- 1) Dig a hole of 50mm diameter for cable exit in the installation wall.
- 2) In Figure 4-2, connect the adapter block to the internal thread of the wall mount bracket, until it reaches the end and then fix the set screw. Pull the intelligent speed dome composite cable through the adapter block and pull it out of the other end of the wall mount bracket. Line up the hook at the top of the external enclosure to the inside hole of the adapter block and then push it to the end, and then secure the three screws of the adapter block firmly. **Please note this step is very important. Please make sure the screws are firm, otherwise, it may result in falling risk of the intelligent speed dome.**

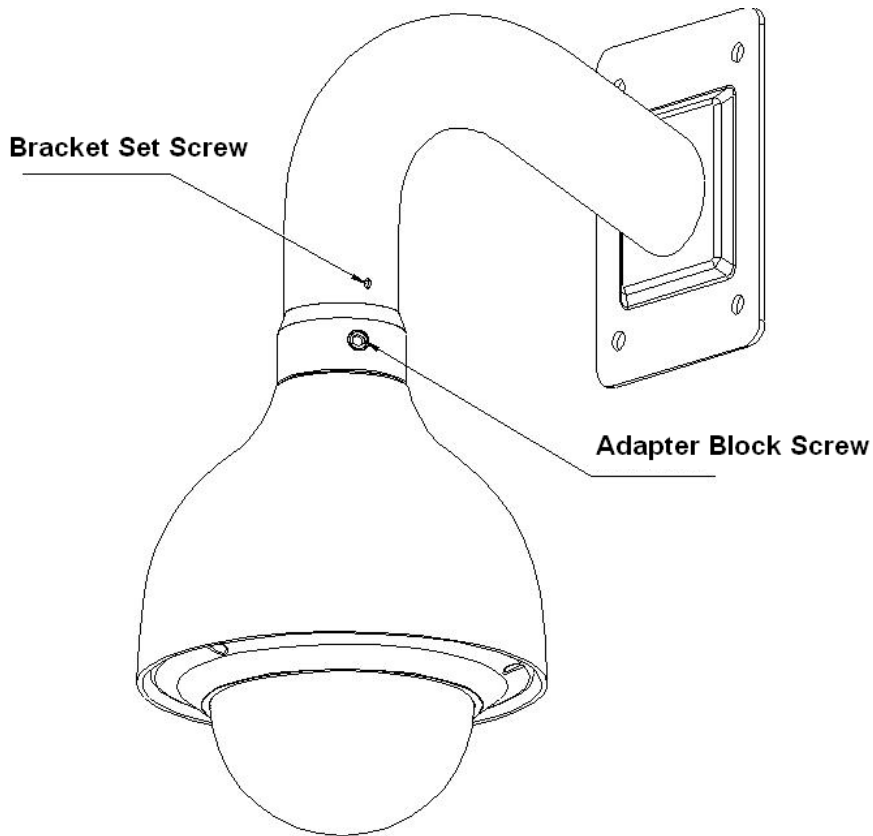

Figure 4-2

- 3) Dig holes in the wall according to the installation holes at the bottom of the wall mount bracket. Please make sure the cable exit of the bracket is facing the round hole of the wall. Insert expansion bolts (not provided) to the holes you just dug. Connect the composition cable and then pull it through the hole in the wall. Use four hex screws and flat washer to secure the bracket on the wall of the expansion bolts. See Figure 4-3.

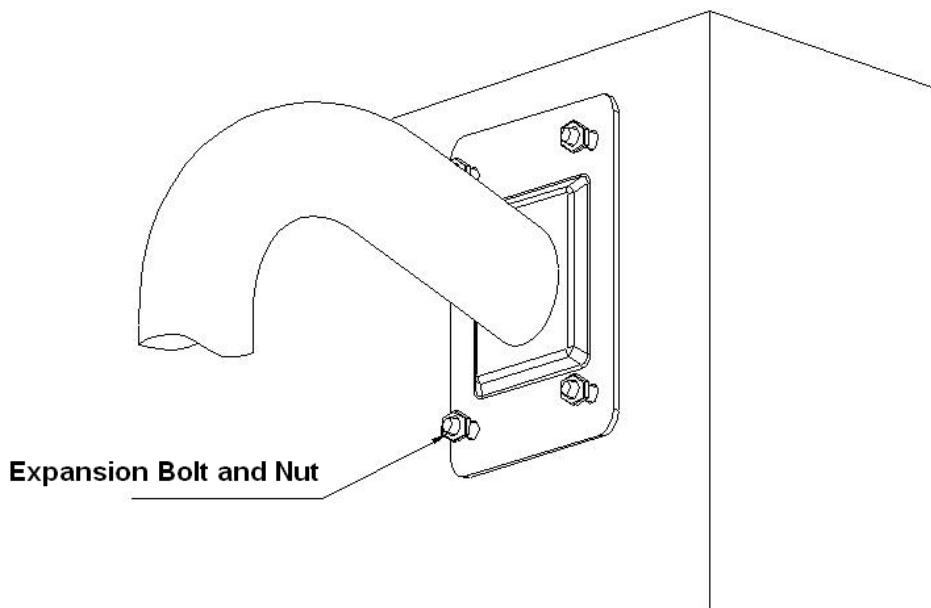

Figure 4-3

Now the installation is complete. See Figure 4-4.

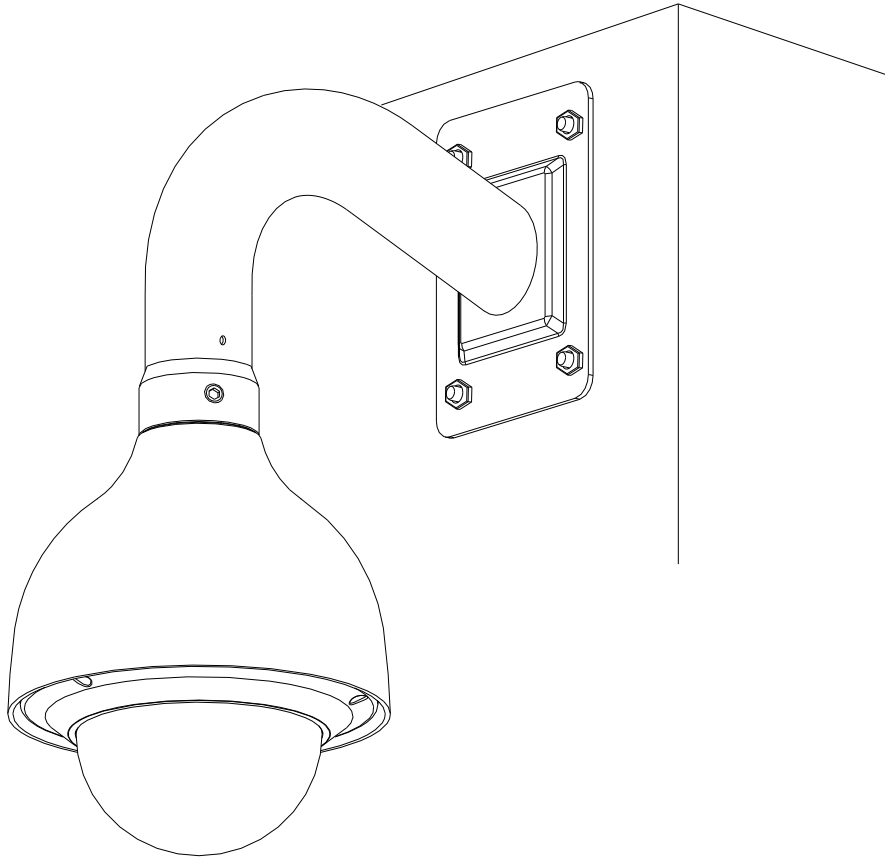

Figure 4-4

5 IN-CEILING MOUNT BRACKET INSTALLATION

5.1 Component Installation

The in-ceiling bracket and speed dome body is shown as below. See Figure 5-1.

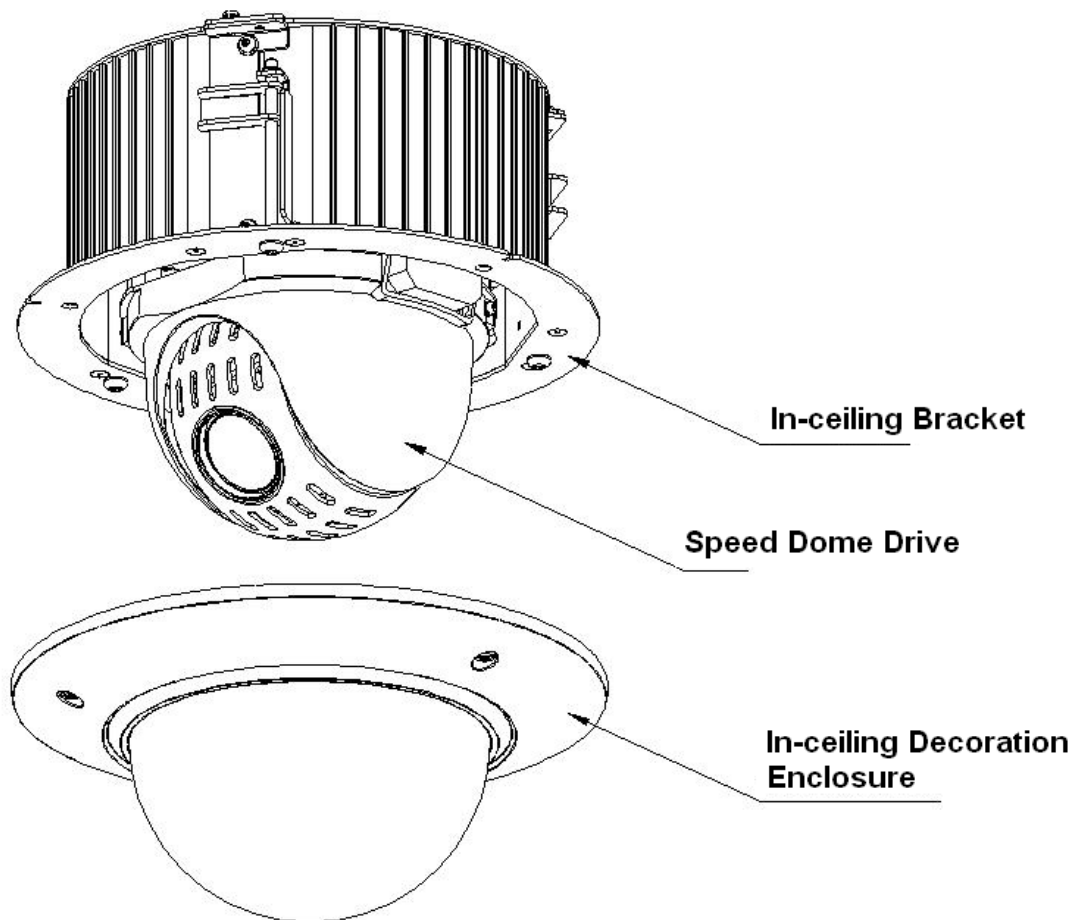

Figure 5-1

5.2 Installation

5.2.1 Installation Requirements

The in-ceiling mount speed dome can be installed in the hard construction wall in the indoor environments. Before the installation, please make sure:

- The ceiling thickness ranges from 10-40mm.
- The ceiling can at least sustain the 8x weight of the speed dome, bracket and the accessories.

5.2.2 Installation Steps

Please confirm installation position and paste the in-ceiling installation position map to dig holes. See Figure 5-2.



Figure 5-2

Connect the composition cable and then put the cable to the hole you just dug. Push the in-ceiling bracket and dome body to the hole you just dug. Turn the fastening screw to secure the hanging board. See Figure 5-3.

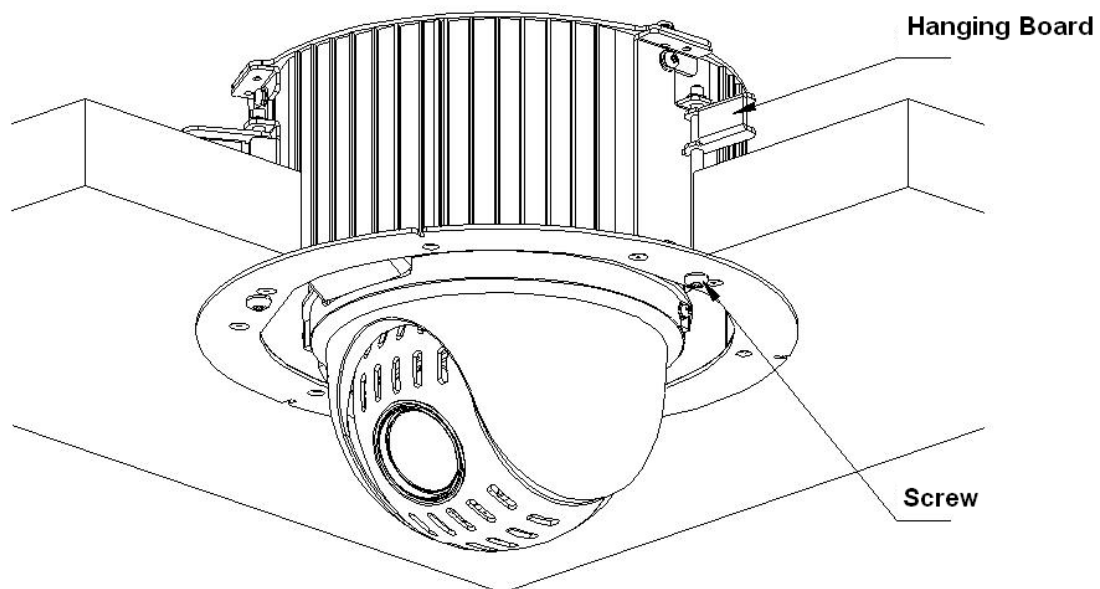

Figure 5-3

In Figure 5-4, use three screws to secure the in-ceiling decoration enclosure component to the in-ceiling bracket components and fix them firmly. See Figure 5-5.

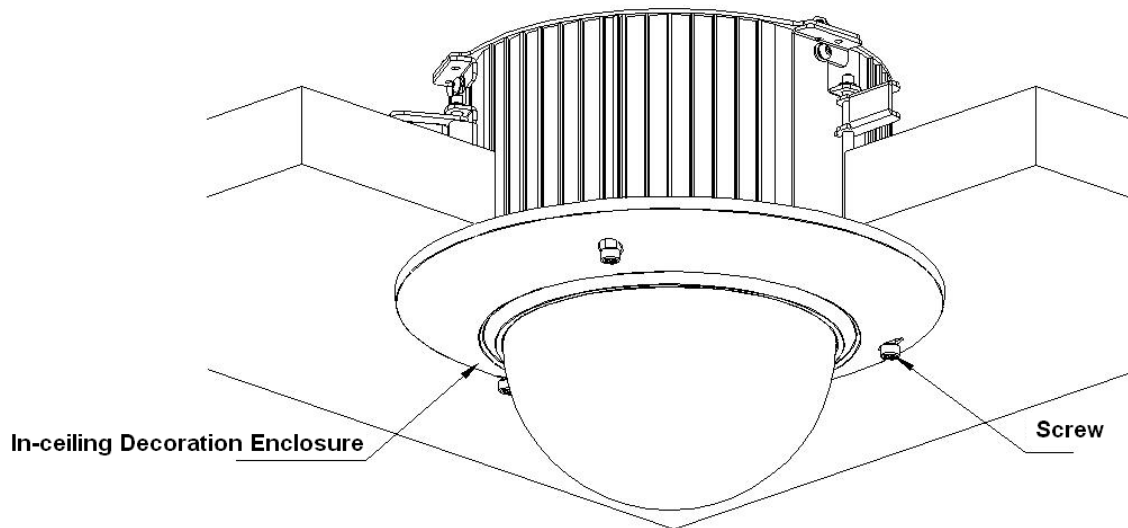

Figure 5-4

After the installation, the interface is shown as in Figure 5-5.

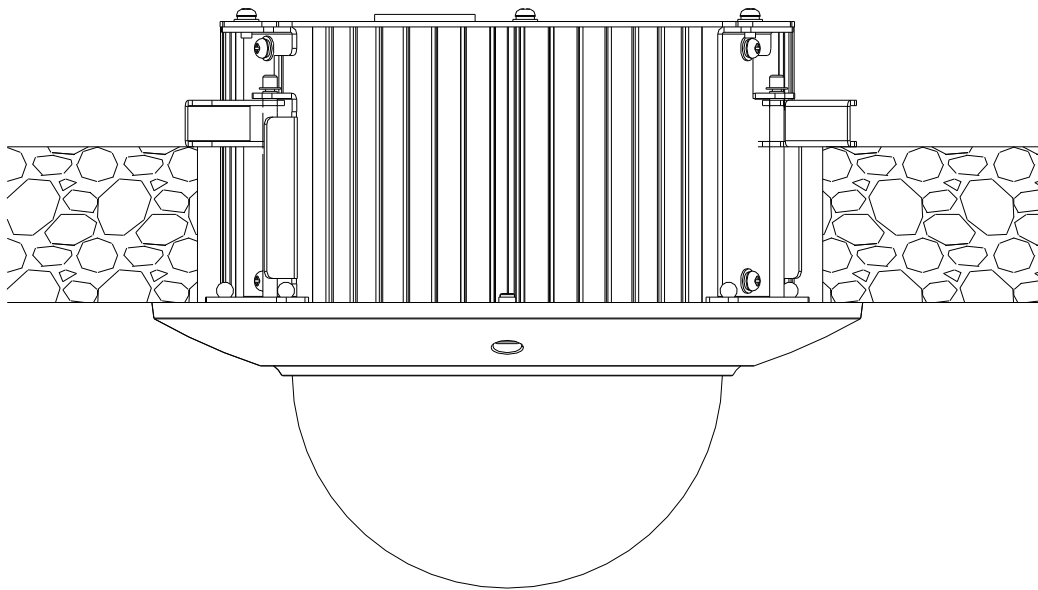

Figure 5-5

6 APPENDIX I THUNDER PROOF AND SURGE PROTECTION

This series speed dome adopts TVS lightning protection technology. It can effectively prevent damages from various pulse signals below 6000V, such as sudden lightning and surge. While maintaining your local electrical safety code, you still need to take necessary precaution measures when installing the speed dome in the outdoor environment.

- The distance between the signal transmission cable and high-voltage device (or high-voltage cable) shall be at least 50 meters.
- Outdoor cable layout shall go under the penthouse if possible.
- For vast land, please use sealing steel tube under the land to implement cable layout and connects one point to the earth. Open floor cable layout is forbidden.
- In area of strong thunderstorm hit or near high sensitive voltage (such as near high-voltage transformer substation), you need to install additional high-power thunder protection device or lightning rod.
- The thunder protection and earth of the outdoor device and cable shall be considered in the building whole thunder protection and conform to your local national or industry standard.
- System shall adopt equal-potential wiring. The earth device shall meet anti-jamming and at the same time conforms to your local electrical safety code. The earth device shall not short circuit to N (neutral) line of high voltage power grid or mixed with other wires. When connect the system to the earth alone, the earth resistance shall not be more than 4Ω and earth cable cross-sectional area shall be below 25 mm^2 . See Figure 6-1.

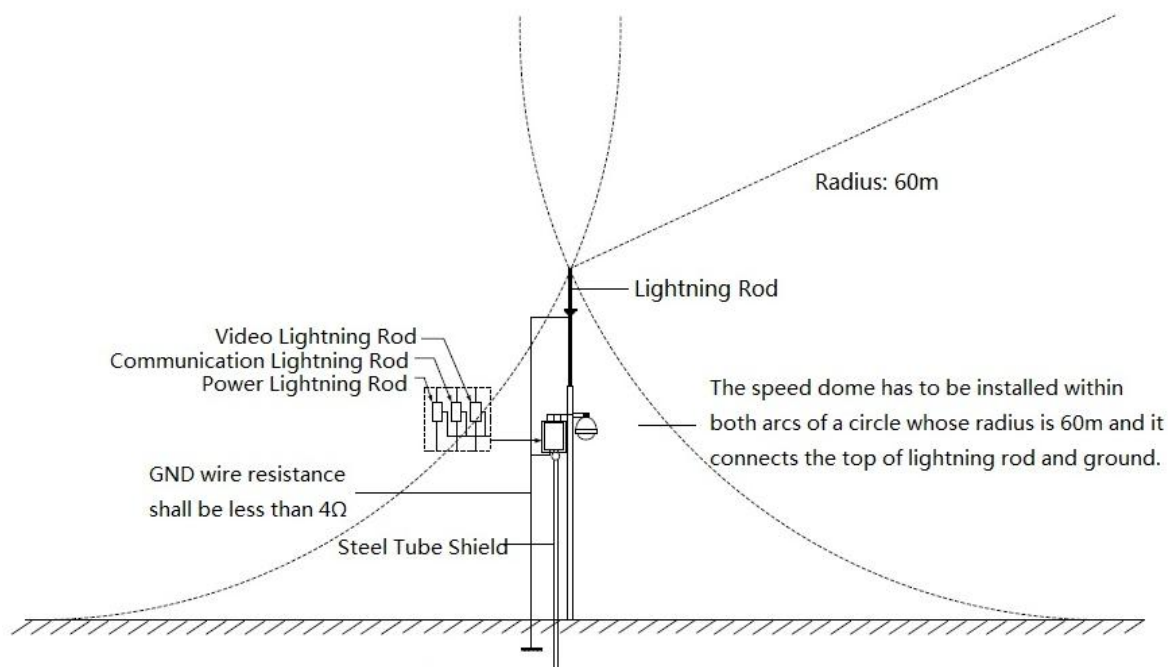

Figure 6-1

7 APPENDIX II ABOUT RS485 BUS

7.1 RS485 Bus Main Feature

RS485 is semi duplex communication cable of impedance 120Ω . Its max load amount is 32 effective loads (including main control device and devices to be charged).

7.2 RS485 Bus Transmission Distance

When we take 0.56mm (24AWG) twisted-pair as communication cable, the max transmission distance (theoretically) are listed below (according to different baud rates).

Baud Rate	Max Distance
2400 BPS	1800M
4800 BPS	1200M
9600 BPS	800M

In the following situations, the max transmission distance shall become shorter accordingly:

- The communication cable is a little bit thin;
- The surrounding environment has strong electromagnetic interference;
- There are too much devices connected to the RS485 bus;

And vice versa, the max transmission distance shall become longer.

7.3 The Problem in Practical Use

In practical usage, we usually adopt star type connection. The terminal resistance shall connect to the furthest two devices (Such as device 1# and device 15# in Figure 7-1). But this connection way does not conform to RS485 Bus standard. When the distances between devices are too long, the signal reflection occurs and anti-jamming decreases, thus the signal reliability becomes very low. You can see speed dome is not under control or speed dome is running automatically and can not stop.

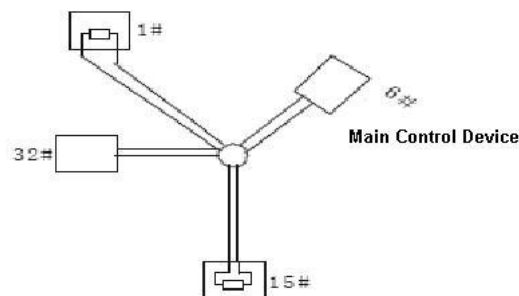

Figure 7-1

In this situation, we recommend RS485 distributor. This device can turn star type connection into the connection that conforms to RS485 bus industry standard, which can avoid the above mentioned problems and enhance communication reliability. See Figure 7-2.

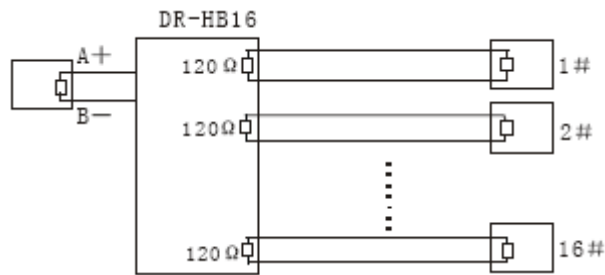

Figure 7-2

7.4 RS485 Bus FAQ

Phenomenon	Possible Reasons	Solution
Speed dome can run self-diagnosis but I can not control it.	<ul style="list-style-type: none"> ● Host address(baud rate) and speed dome address(baud rate) are not match; ● Positive and negative end of RS485 Bus are misconnected; ● Connection cable is loose; ● RS485 Bus connection are cut off; 	<ul style="list-style-type: none"> ● Modify host or speed dome setup ; ● Switch RS485 positive end and negative end; ● Fix connection cable firmly; ● Replace RS485 Bus.
I can control the speed dome but is not smooth	<ul style="list-style-type: none"> ● RS485 Bus connection are not good; ● One RS485 bus is off; ● The distance between host and speed dome is too far; ● Parallel connected too much speed domes. 	<ul style="list-style-type: none"> ● Connect RS 485 Bus again; ● Replace RS485 Bus; ● Add terminal matching resistance; ● Add RS485 distributor.

8 APPENDIX III THE 24V AC WIRE GAUGE AND

TRANSMISSION DISTANCE RELATIONSHIP SHEET

It is the recommended transmission distance when the cable diameter is fixed and the 24V AC power consumption is below 10%. For the AC device, the max permission voltage power consumption is 10%. For example, when a device of rated power 20W installed from the transformer 141 inches (42m), then the min cable diameter is 0.8000mm.

For this series product, you can refer to the following information:

- **Ceiling and in-ceiling series product, please select the wire of the 20W transmission power.**
- **For outdoor intelligent speed dome, please select the wire of the 30W transmission power.**

Feet(m) W	mm	0.8000	1.000	1.250	2.000
	10		283 (86)	451 (137)	716 (218)
20		141 (42)	225 (68)	358 (109)	905 (275)
30		94 (28)	150 (45)	238 (72)	603 (183)
40		70 (21)	112 (34)	179 (54)	452 (137)
50		56 (17)	90 (27)	143 (43)	362 (110)
60		47 (14)	75 (22)	119 (36)	301 (91)
70		40 (12)	64 (19)	102 (31)	258 (78)
80		35 (10)	56 (17)	89 (27)	226 (68)
90		31 (9)	50 (15)	79 (24)	201 (61)
100		28 (8)	45 (13)	71 (21)	181 (55)
110		25 (7)	41 (12)	65 (19)	164 (49)
120		23 (7)	37 (11)	59 (17)	150 (45)
130		21 (6)	34 (10)	55 (16)	139 (42)
140		20 (6)	32 (9)	51 (15)	129 (39)
150		18 (5)	30 (9)	47 (14)	120 (36)
160		17 (5)	28 (8)	44 (13)	113 (34)
170		16 (4)	26 (7)	42 (12)	106 (32)
180		15 (4)	25 (7)	39 (11)	100 (30)
190		14 (4)	23 (7)	37 (11)	95 (28)
200		14 (4)	22 (6)	35 (10)	90 (27)

9 APPENDIX IV 12V AC WIRE GAUGE AND

TRANSMISSION DISTANCE RELATIONSHIP SHEET

The recommended max transmission distance is under the following environments: The wire diameter is fixed and the DC 12V power voltage loss rate is below 10%. For the device of DC power supplying, the max allowed voltage loss rate is 10%.

W Feet (m)	mm	0.8000	1.000	1.250	2.000
	10	62 (18)	96 (29)	151 (45)	387 (116)
12	51 (15)	80 (24)	126 (37)	323 (96)	
15	41 (12)	64 (19)	100 (30)	258 (77)	
20	31 (9)	48 (14)	75 (22)	193 (58)	
30	20 (6)	32 (9)	50 (15)	129 (38)	
40	15 (4)	24 (7)	37 (11)	96 (29)	
50	12 (3)	19 (5)	30 (9)	77 (23)	

Note

All the wires listed in the above sheet are copper wire. (Copper wire resistance

$$\rho = 0.0175\Omega * \text{mm}^2/\text{m})$$

10 APPENDIX V WIRE GAUGE REFERENCE SHEET

Metric bare wire diameter (mm)	AWG	SWG	Bare wire cross section (mm ²)
0.050	43	47	0.00196
0.060	42	46	0.00283
0.070	41	45	0.00385
0.080	40	44	0.00503
0.090	39	43	0.00636
0.100	38	42	0.00785
0.110	37	41	0.00950
0.130	36	39	0.01327
0.140	35		0.01539
0.160	34	37	0.02011
0.180	33		0.02545
0.200	32	35	0.03142
0.230	31		0.04115
0.250	30	33	0.04909
0.290	29	31	0.06605
0.330	28	30	0.08553
0.350	27	29	0.09621
0.400	26	28	0.1257
0.450	25		0.1602
0.560	24	24	0.2463
0.600	23	23	0.2827
0.710	22	22	0.3958
0.750	21		0.4417
0.800	20	21	0.5027
0.900	19	20	0.6362
1.000	18	19	0.7854
1.250	16	18	1.2266
1.500	15		1.7663
2.000	12	14	3.1420
2.500			4.9080
3.000			7.0683

Note

- This manual is for reference only. Slight difference may be found in the user interface.
- All the designs and software here are subject to change without prior written notice.
- All trademarks and registered trademarks are the properties of their respective owners.

-
- **If there is any uncertainty or controversy, please refer to the final explanation of us.**
 - **Please visit our website or contact your local service engineer for more information.**