

HD IR Waterproof Fixed Network Camera User's Manual

Version 4.0.2

Welcome

Thank you for purchasing our network camera!

This user's manual is designed to be a reference tool for your system.

Please read the following safeguard and warnings carefully before you use this series product!

Please keep this user's manual well for future reference!

Important Safeguards and Warnings

1 . Electrical safety

All installation and operation here should conform to your local electrical safety codes.

The power shall conform to the requirement in the SELV (Safety Extra Low Voltage) and the Limited power source is rated 12V DC or 24V AC in the IEC60950-1. (Refer to general introduction) **Please note: Do not connect two power supplying sources to the device at the same time; it may result in device damage!**

We assume no liability or responsibility for all the fires or electrical shock caused by improper handling or installation.

We are not liable for any problems caused by unauthorized modification or attempted repair.

2 . Transportation security

Heavy stress, violent vibration or water splash are not allowed during transportation, storage and installation.

3 . Installation

Do not apply power to the camera before completing installation.

Please install the proper power cut-off device during the installation connection.

Always follow the instruction guide the manufacturer recommended.

4 . Qualified engineers needed

All the examination and repair work should be done by the qualified service engineers.

We are not liable for any problems caused by unauthorized modifications or attempted repair.

5 . Environment

This series network camera should be installed in a cool, dry place away from direct sunlight, inflammable, explosive substances and etc.

Please keep it away from the electromagnetic radiation object and environment.

Please make sure the CCD (CMOS) component is out of the radiation of the laser beam device.

Otherwise it may result in CCD (CMOS) optical component damage.

Please keep the sound ventilation.

Do not allow the water and other liquid falling into the camera.

Thunder-proof device is recommended to be adopted to better prevent thunder.

The grounding studs of the product are recommended to be grounded to further enhance the reliability of the camera.

6. Daily Maintenance

Please shut down the device and then unplug the power cable before you begin daily maintenance work.

Do not touch the CCD (CMOS) optic component. You can use the blower to clean the dust on the lens surface.

Always use the dry soft cloth to clean the device. If there is too much dust, please use the water to dilute the mild detergent first and then use it to clean the device. Finally use the dry cloth to clean the device.

Please put the dustproof cap to protect the CCD (CMOS) component when you do not use the camera. Dome enclosure is the optical component, do not touch the enclosure when you are installing the device or clean the enclosure when you are doing maintenance work. Please use professional optical clean method to clean the enclosure. Improper enclosure clean method (such as use cloth) may result in poor IR effect of camera with IR function.

7. Accessories

Be sure to use all the accessories recommended by manufacturer.

Before installation, please open the package and check all the components are included.

Contact your local retailer ASAP if something is broken in your package.

Accessory Name	Amount
Network Camera Unit	1
Quick Start Guide	1
CD	1

Table of Contents

1	General Introduction.....	1
1.1	Overview	1
1.2	Features	1
1.3	Specifications	2
1.3.1	Performance	2
2	Structure.....	4
2.1	Multiple-function Combination Cable	4
2.2	Framework and Dimension	5
2.3	Bidirectional talk.....	6
2.3.1	Device-end to PC-end.....	6
2.3.2	PC-end to the Device-end.....	6
2.4	Alarm Setup.....	6
3	Device Installation	9
4	Quick Configuration Tool	10
4.1	Overview	10
4.2	Operation	10
5	Web Operation.....	12
5.1	Network Connection.....	12
5.2	Login and Main Interface.....	12
6	FAQ.....	15
	Appendix Toxic or Hazardous Materials or Elements.....	16

1 General Introduction

1.1 Overview

This series network camera integrates the traditional camera and network video technology. It adopts audio and video data collection, transmission together. It can connect to the network directly without any auxiliary device.

This series network camera uses standard H.264 video compression technology and G.711a audio compression technology, which maximally guarantee the audio and video quality.

It supports the IR night vision function. In the night environments, the device can use the IR light to highlight the object which is suitable for the surveillance function in the low illumination environments. The built-in protection enclosure and waterproof design conforms to the IP 66 level. It has the sound waterproof function suitable for use in the outdoor environments.

It supports real-time monitor and listening at the same time. It supports analog video output and dual-way bidirectional talk.

It can be used alone or used in a network area. When it is used lonely, you can connect it to the network and then use a network client-end. Due to its multiple functions and various uses, this series network camera is widely used in many environments such office, bank, road monitor and etc.

1.2 Features

User Management	<ul style="list-style-type: none">● Different user rights for each group, one user belongs to one group.● The user right shall not exceed the group right.
Storage Function	<ul style="list-style-type: none">● Support central server backup function in accordance with your configuration and setup in alarm or schedule setting● Support record via Web and the recorded file are storage in the client-end PC.● Support built-in SD card.● Do not support local SD card hot swap storage function. Support short-time storage when encounter disconnection.● Support network storage function such as FTP.
Alarm Function	<ul style="list-style-type: none">● Real-time respond to external on-off alarm input, and video detect as user pre-defined activation setup and generate corresponding message in screen and audio prompt(allow user to pre-record audio file)● Real-time video detect: motion detect, tampering.
Network Monitor	<ul style="list-style-type: none">● Network camera supports one-channel audio/video data transmit to network terminal and then decode. Delay is within 270ms (network bandwidth support needed)● Max supports 20 connections.● Adopt the following audio and video transmission protocol: HTTP, TCP, UDP, MULTICAST, RTP/RTCP, RTSP and etc.● Support web access.
Network Management	<ul style="list-style-type: none">● Realize network camera configuration and management via Ethernet.● Support device management via web or client-end.
Power	<ul style="list-style-type: none">● External power adapter DC12V/AC 24V. You can select according to your actual environments. Please note system can not support these two types of power supplying at the same time.

Assistant Function	<ul style="list-style-type: none"> ● Log function ● Support system resource information and running status real-time display. ● Day/Night mode auto switch. ● Built-in IR light. Support IR night vision. ● Support picture parameter setup such as electronic shutter and gain setup. ● Backlight compensation: screen auto split to realize backlight compensation to adjust the bright. ● Support video watermark function to avoid vicious video modification. ● The enclosure conforms to the IP 66 protection. Has the waterproof function.
---------------------------	---

1.3 Specifications

1.3.1 Performance

Please refer to the following sheet for network camera performance specification.

Model		IPC-HFW3300 Series	IPC-HFW3110 Series	
Parameter				
System	Main Processor	TI Davinci high performance DSP		
	OS	Embedded LINUX		
	System Resources	Support real-time network, local record, and remote operation at the same time.		
	User Interface	Remote operation interface such as WEB, DSS, PSS		
	System Status	SD card status, bit stream statistics, log, and software version.		
Video Parameter	Image Sensor	1/2.8-inch CMOS	1/3-inch CCD	
	Pixel	2048(H)*1536(V)	1280(H)*960(V)	
	Day/Night Mode	Support day/night mode switch and IR-CUT at the same time.		
	Auto Aperture	DC drive		
	Gain Control	Fixed/Auto		
	White Balance	Manual/Auto		
	BLC	Off/BLC/WDR (1-100)/HLC(anti-flicker is outdoor and is valid only when exposure mode is auto with range 1-100)		
	Exposure Mode	Auto/Low noise/Low motion blur/ Manual It ranges from 1/3 to 1/10000	Manual/Auto It ranges from 1/3 to 1/100000.	
	Video Compression Standard	H.264/H.264H/H.264B/MJPEG Note: Some versions do not support H.264H.		
	Video Frame Rate		PAL: Main stream (2048*1536@18fps), extra stream (704*576@18fps) Main stream (1920*1080@25fps), extra stream (704*576@25fps)	PAL: Main stream (1280*960@12fps), extra stream (704*576@12fps) Main stream (1280*720@25fps), extra stream (704*576@25fps)
			NTSC: Main stream (2048*1536@20fps), extra stream (704*480@20fps) Main stream (1920*1080@30fps), extra stream(704*480@30fps)	NTSC: Main stream (1280*960@22fps), extra stream (704*480@22fps) Main stream (1280*720@30fps), extra stream (704*480@30fps)
Video Bit Rate	H.264: 56Kbps-8192Kbps			

		MJPEG: adjustable and bit rate is adjustable. Support customized setup.	
	Video Flip	Support mirror and flip function.	
	Snapshot	Max 1f/s snapshot. File extension name is JPEG.	
	Privacy Mask	Supports max 4 privacy mask zones	
	Video Setup	Support parameter setup such as bright, contrast.	
	Video Information	Channel title, time title, motion detect, tampering.	
	Lens	8~16mm @F1.6	8~20mm@F1.6
	Lens Interface	C/CS. Lens is the default accessories	
Audio	Audio Input	1-channel,LINE IN	
	Audio Output	1-channel, 3.5mm JACK SPEAK OUT.	
	Bidirectional Talk Input	Reuse the first audio input channel	
	Audio Bit Rate	16kbps 16BIT	
	Audio Compression Standard	G.711A/G.711Mu	
Video	Motion Detect	396 (18*22) detection zones; sensitivity level ranges from 0 to 100; area threshold ranges from 0 to 100. Activation event: video storage, image snapshot, log, email function and etc.	
Alarm Input		2-channel input,1-channel output	
Record and Backup	Record Priority	Manual>External alarm >Video detect>Schedule	
	Storage Management	Support SD card storage, NAS storage	
Network	Wire Network	1-channel wire Ethernet port, 10/100 Base-T Ethernet	
	Network Protocol	HTTP,TCP,ARP,RTSP,RTP,UDP,RTCP,SMTP,FTP,DHCP,DNS,DDNS,PPPOE,IPv4/v6,SNMP,QoS,UPnP,NTP, HTTPS, 802.1x, Bonjour	
	Protocol	PSIA (optional), ONVIF	
	Remote Operation	Monitor, system setup, file download, log information, maintenance , upgrade and etc	
AUX Interface	Video Output	1-channel analog video output,BNC port, 9-pin port connection	
	Reset	9-pin port connection	
	IR light	42 LED, IR distance 20 to 30 meters. 70 LED, IR distance 30 to 50 meters.	56 LED, IR distance 30 to 50 meters.
General Parameter	Power	Support AC24V/DC12V power.	
	Power Consumption	For -IR2 device: 8W MAX (10W MAX when ICR switch) For -IR4 device:10W MAX (12W MAX when ICR switch)	12W MAX (14W MAX when ICR switch)
	Working Temperature	-20°C~+60°C	
	Working Humidify	≤95%	
	Dimensions(mm)	288x118x101	
	Weight	2468g(Excluding box)	
	Installation	Support various installation modes (Bracket is optional)	

2 Structure

2.1 Multiple-function Combination Cable

You can refer to the following figure for multiple-function combination cable information. See Figure 2-1.

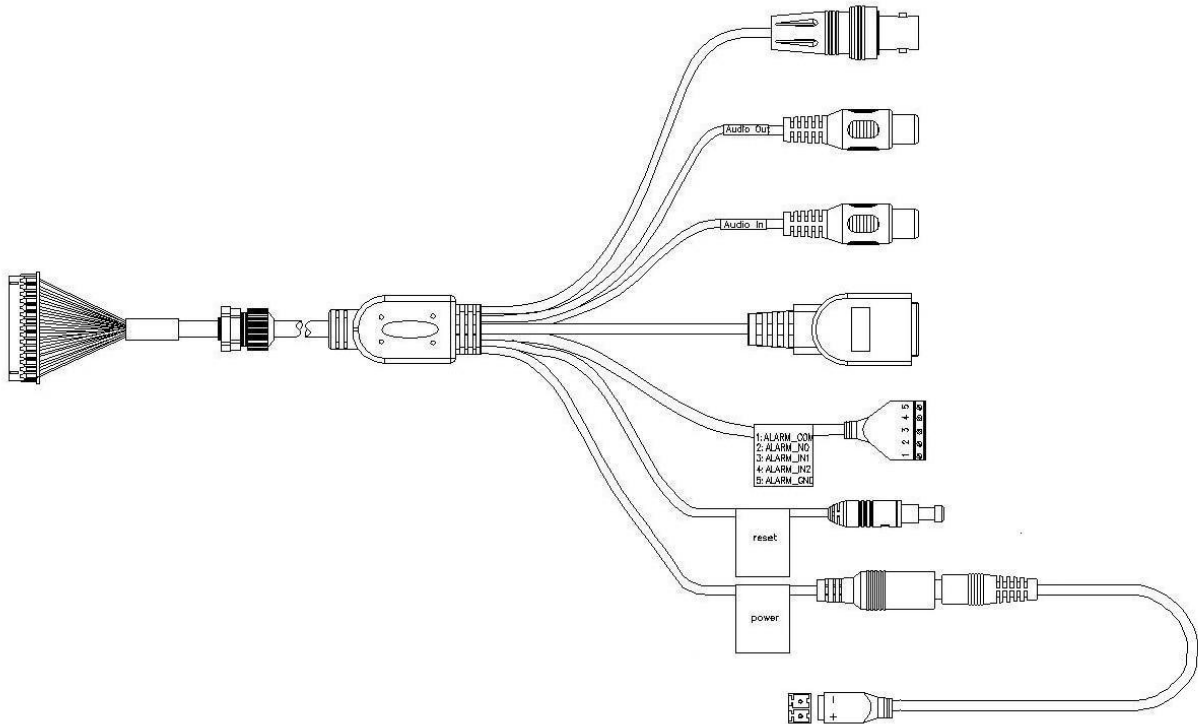

Figure 2-1 Multiple-function combination cable

Please refer to the following sheet for detailed information.

SN	Port Name	Function	Connection	Note
1	VIDEO OUT	Video output port	BNC	Output analog video signal. It can connect to the TV monitor to view the video.
2	AUDIO IN	Audio input port	RCA	Input audio signal. It can receive the analog audio signal from the pickup.
3	AUDIO OUT	Audio output port	RCA	Output audio signal to the devices such as the sound box.
4	LAN	Network port	Ethernet port	<ul style="list-style-type: none"> ● Connect to standard Ethernet cable. ● Support PoE.
5	I/O	I/O cable port	/	Includes alarm input and output.
6	RESET	Reset button	/	The reset button is to restore device factory default setup.

SN	Port Name	Function	Connection	Note
7	POWER	Power input port	/	Power port. Input DC 12V or AC 24V. Default is a DC 5.5 round port to 2-pin converter cable Please note: Connect the DC5.5 round port to 2-pin converter cable (Provided) when you are using AC 24V series product.

Please refer to the follow sheet for detailed pin information

Port Name	SN	Name	Note
I/O Port	1	ALARM_COM	Alarm output public port.
	2	ALARM_NO	Alarm output port. It is to output the alarm signal to the alarm device. NO: normal open alarm output port.
	3	ALARM_IN1	Alarm input port 1. It is to receive the on-off signal from the external alarm source.
	4	ALARM_IN2	Alarm input port 2. It is to receive the on-off signal from the external alarm source.
	5	GND	Ground port

2.2 Framework and Dimension

Please refer to the following two figures for dimension information. The unit is mm. See Figure 2-2 and Figure 2-3.

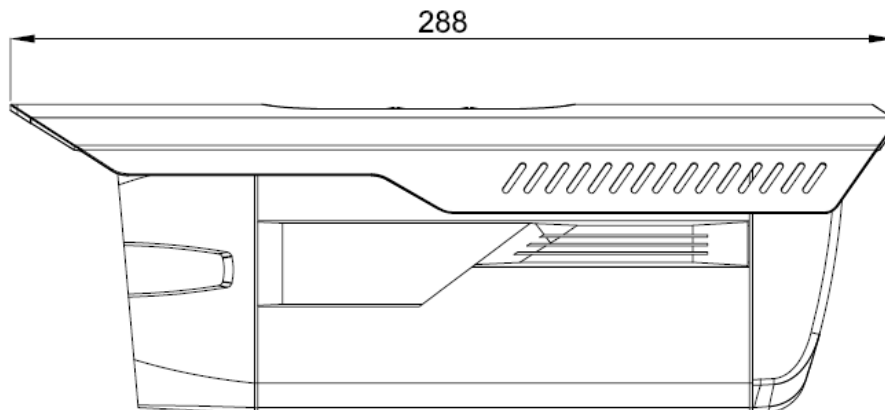

Figure 2-2 Dimension illustration 1

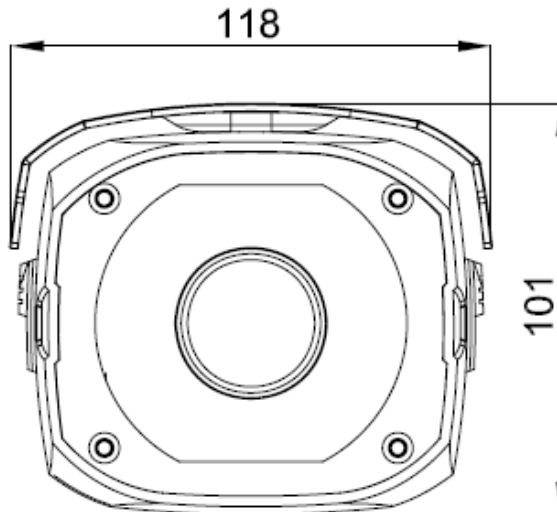

Figure 2-3 Dimension illustration 2

2.3 Bidirectional talk

2.3.1 Device-end to PC-end

Device Connection

Please connect the speaker or the MIC to the audio input port of the device. Then connect the earphone to the audio output port of the PC.

Login the Web and then click the Talk button to enable the bidirectional talk function.

You can see the button becomes orange after you enabled the bidirectional talk function.

Click Talk button again to stop the bidirectional talk function.

Listening Operation

At the device end, speak via the speaker or MIC, and then you can get the audio from the earphone or sound box at the pc-end.

2.3.2 PC-end to the Device-end

Device Connection

Connect the speaker or the MIC to the audio input port of the PC and then connect the earphone to the audio output port of the device.

Login the Web and then click the Talk button to enable the bidirectional talk function.

You can see the button becomes orange after you enabled the audio talk function.

Click Talk button again to stop the bidirectional talk function.

Please note the on-site listening operation is null during the bidirectional talk process.

Listening Operation

At the PC-end, speak via the speaker or MIC, and then you can get the audio from the earphone or sound box at the device-end.

2.4 Alarm Setup

The alarm interface is shown as in Figure 2-4. Please follow the steps listed below for local alarm input and output connection.

1) Connect the alarm input device to the alarm input port (No.3 pin or No.4 pin) of the I/O cable.

- 2) Connect the alarm output device to the alarm output port (No.2 pin) and alarm output public port (No.1 pin). The alarm output port supports NO (normal open) alarm device only.
- 3) Open the Web, go to the Figure 2-4. Please set the alarm input 01 port for the first channel of the I/O cable (No.3 pin). The alarm input 02 is for the 2nd channel of I/O cable (No.4 pin). Then you can select the corresponding type (NO/NC.)
- 4) Set the WEB alarm output. The alarm output 01 is for the alarm output port of the device. It is the No.2 pin of the I/O cable.

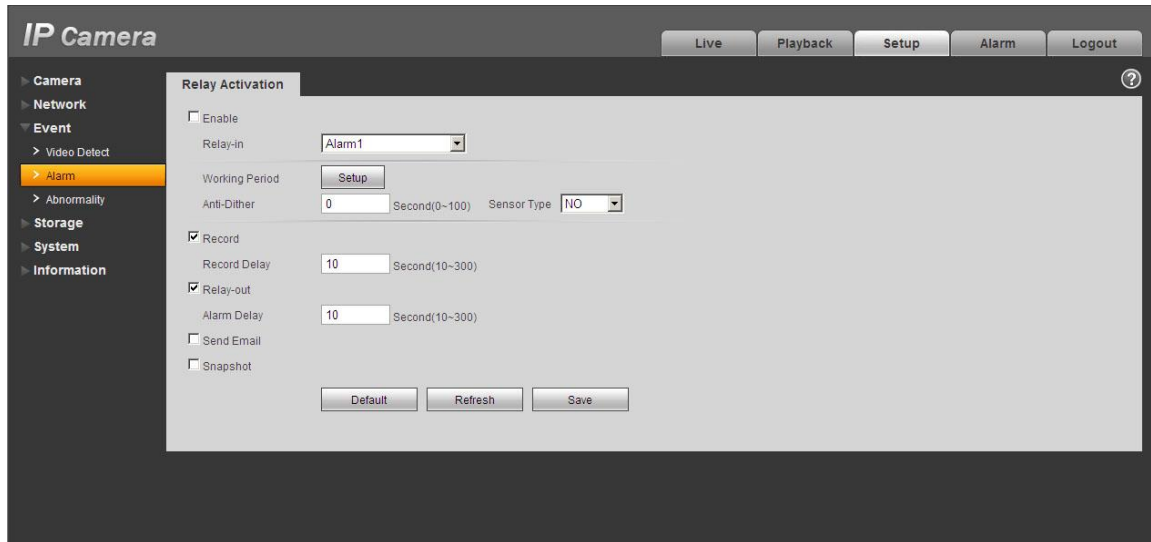

Figure 2-4 Alarm

Please refer to the following figure for alarm input information. See Figure 2-5.

Alarm input: When the input signal is idle or grounded, the device can collect the different statuses of the alarm input port. When the input signal is connected to the 5V or is idle, the device collects the logic “1”. When the input signal is grounded, the device collects the logic “0”.

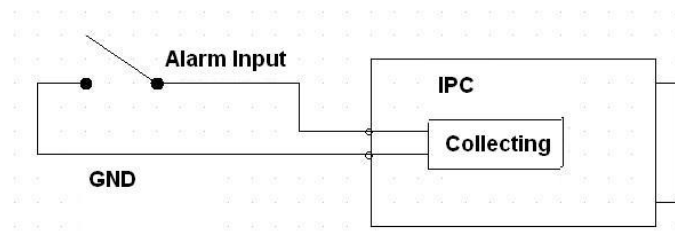

Figure 2-5 Alarm input

Please refer to the following figure for alarm output information. See Figure 2-6.

Port NO and Port C composes an on-off button to provide the alarm output.

If the type is NO, this button is normal open. The button becomes on when there is an alarm output.

If the type is NC, this button is normal off. The button becomes off when there is an alarm output.

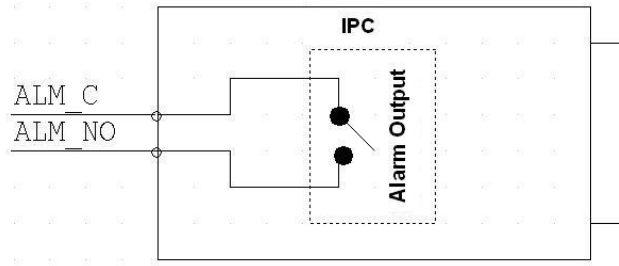

Figure 2-6 Alarm output

3 Device Installation

Please follow the steps listed below to install the device. Please refer to Figure 3-1 for reference.

- Please line up the installation holes of the bottom of the device to the installation holes in the front part of the bracket. Then insert the screws to the holes to fasten the device on the bracket.
- Dig four holes in the wall or the surface, and then input the expansion bolts to the holes and secure.
- Put the four fixed holes of the bottom of the bracket to the four holes you just dug in the wall or surface. Put the four fixed screws to the four holes of the bracket and then secure firmly. Finally you can fix the bracket in the wall or surface.

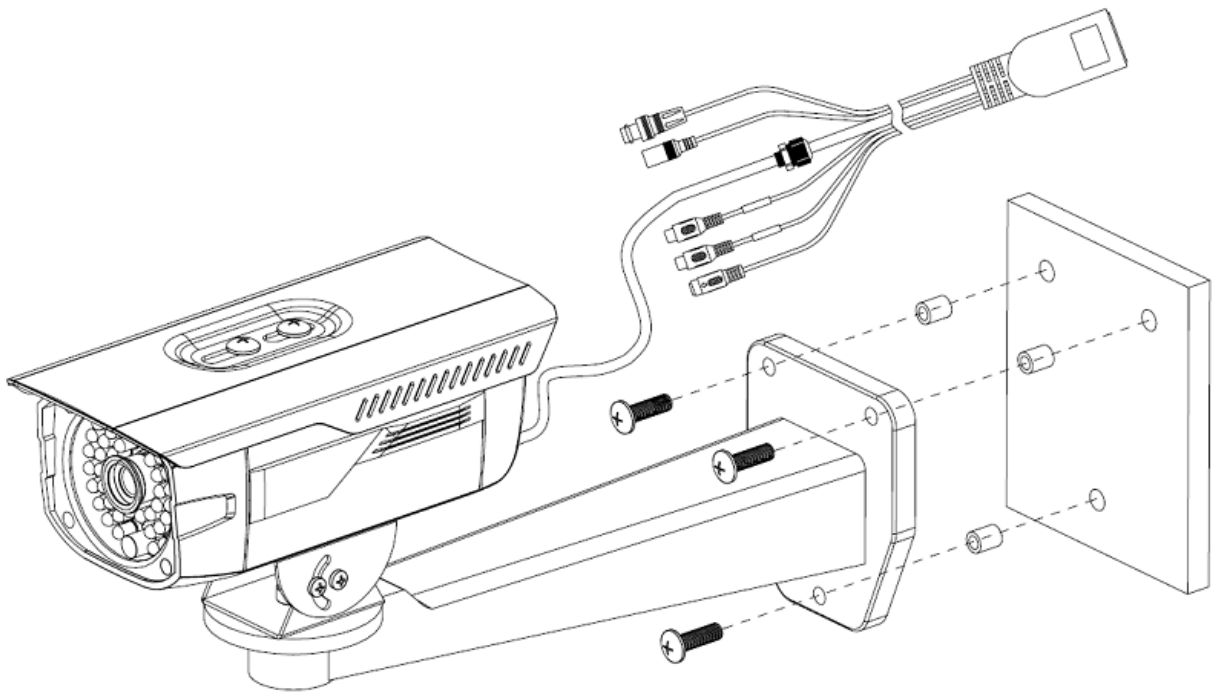

Figure 3-1 Device installation illustration 1

4 Quick Configuration Tool

4.1 Overview

Quick configuration tool can search current IP address, modify IP address. At the same time, you can use it to upgrade the device.

Please note the tool only applies to the IP addresses in the same segment.

4.2 Operation

Double click the “ConfigTools.exe” icon, you can see an interface is shown as in Figure 4-1.

In the device list interface, you can view device IP address, port number, subnet mask, default gateway, MAC address and etc.

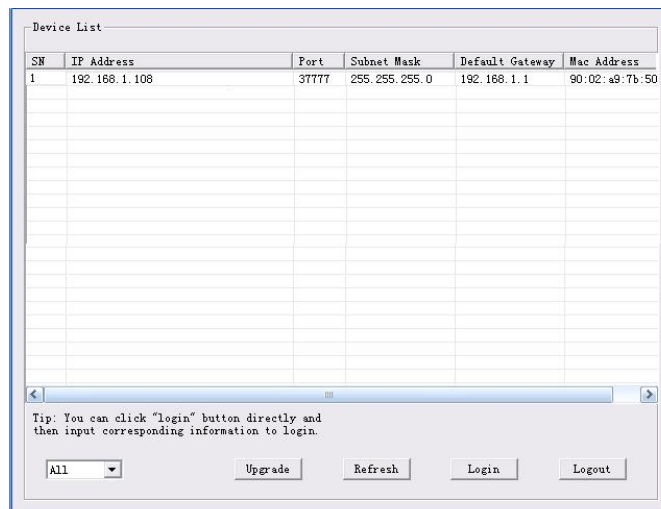

Figure 4-1 Search interface

Select one IP address and then right click mouse, you can see an interface is shown as in Figure 4-2.

Select the “Open Device Web” item; you can go to the corresponding web login interface.

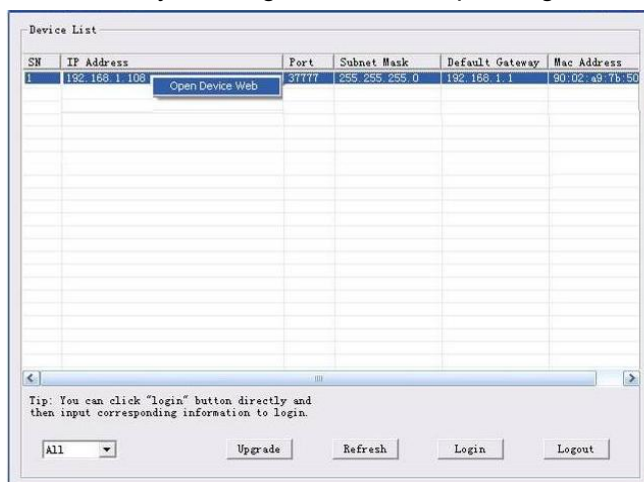

Figure 4-2 Search interface 2

If you want to modify the device IP address without logging in the device web interface, you can go to the configuration tool main interface to set.

In the configuration tool search interface (Figure 4-1), please select a device IP address and then double click it to open the login interface. Or you can select an IP address and then click the Login button to go to the login interface. See Figure 4-3.

In Figure 4-3, you can view device IP address, user name, password and port. Please modify the corresponding information to login.

Please note the port information here shall be identical with the port value you set in TCP port in Web Network interface. Otherwise, you cannot login the device.

If you are using device background upgrade port 3800 to login, other setups are all invalid.

A screenshot of a 'Login' dialog box. It has a title bar with 'Login' and a close button. The dialog contains four input fields: 'IP Address' with '192.168.1.108', 'User Name' with 'admin', 'Password' with '*****', and 'Port' with '37777'. At the bottom, there are two buttons: 'Login' and 'Cancel'.

Figure 4-3 Login prompt

After you logged in, the configuration tool main interface is shown as below. See Figure 4-4.

A screenshot of the main configuration interface. At the top, there are tabs: 'Network Parameter', 'PPPOE', 'System Information', and 'System Upgrade'. The 'Network Parameter' tab is active. Below the tabs, there is a 'General Parameter' section. It includes a checkbox for 'DHCP Enable' (unchecked) and a dropdown menu for 'IPv4'. Below these are five input fields: 'IP Address' (192.168.1.108), 'Subnet Mask' (255.255.0.0), 'Gateway' (10.15.0.1), and 'Mac Address' (90:02:a9:7f:d8:21). At the bottom right, there are two buttons: 'Save' and 'Return'.

Figure 4-4 Main interface

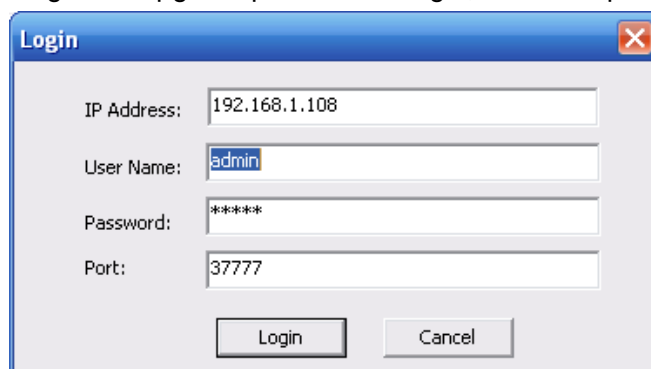
For detailed information and operation instruction of the quick configuration tool, please refer to the *Quick Configuration Tool User's Manual* included in the resources CD.

5 Web Operation

This series network camera products support the Web access and management via PC. Web includes several modules: Monitor channel preview, system configuration, alarm and etc.

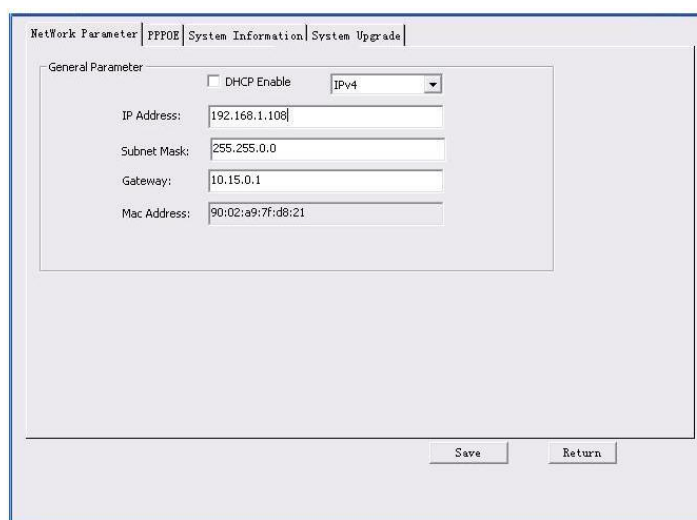
5.1 Network Connection

Please follow the steps listed below for network connection.

- Make sure the network camera has connected to the network properly.
- Please set the IP address, subnet mask and gateway of the PC and the network camera respectively. Network camera default IP address is 192.168.1.108. Subnet mask is 255.255.255.0. Gateway is 192.168.1.1
- Use order ping `***.***.***.***`(* network camera address) to check connection is OK or not.

5.2 Login and Main Interface

Open IE and input network camera address in the address bar. See Figure 5- 1.

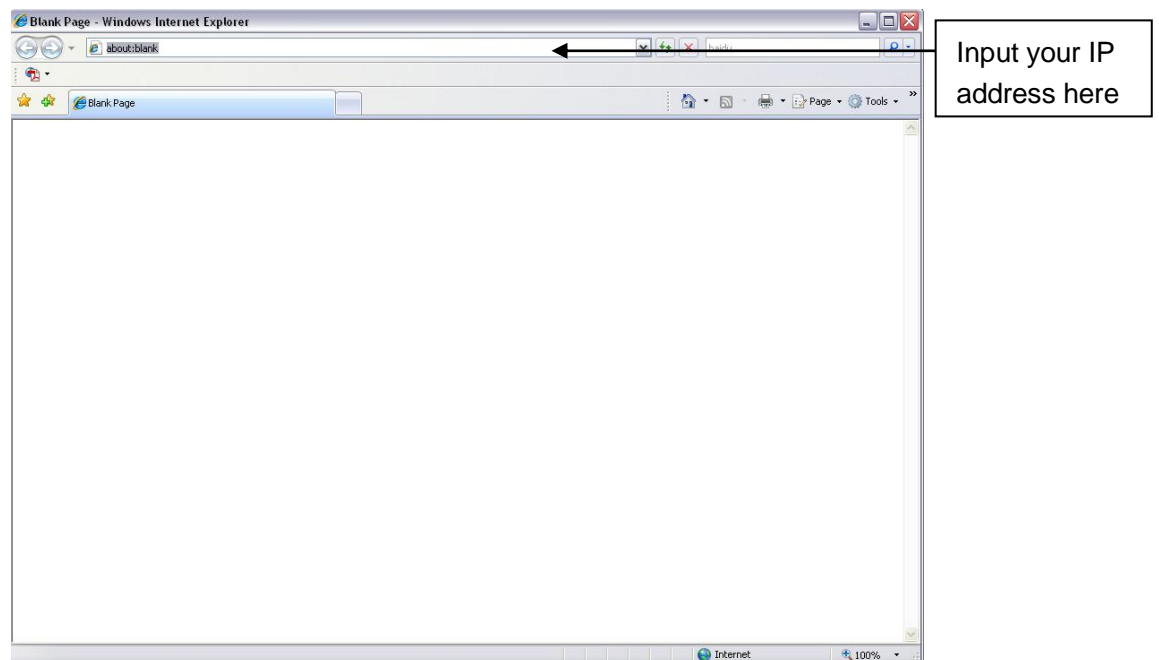

Figure 5- 1 IP address

The login interface is shown as below. See Figure 5- 2.

Please input your user name and password.

Default factory name is admin and password is admin.

Note: For security reasons, please modify your password after you first login.



Figure 5- 2 Web login

If it is your first time to log in, system pops up warning information to ask you whether install web plug-in or not after you logged in for one minute. For detailed plug-in installation, please refer to the Web Operation Manual included in the resource CD.

After you logged in, you can see the main window. See Figure 5- 3.

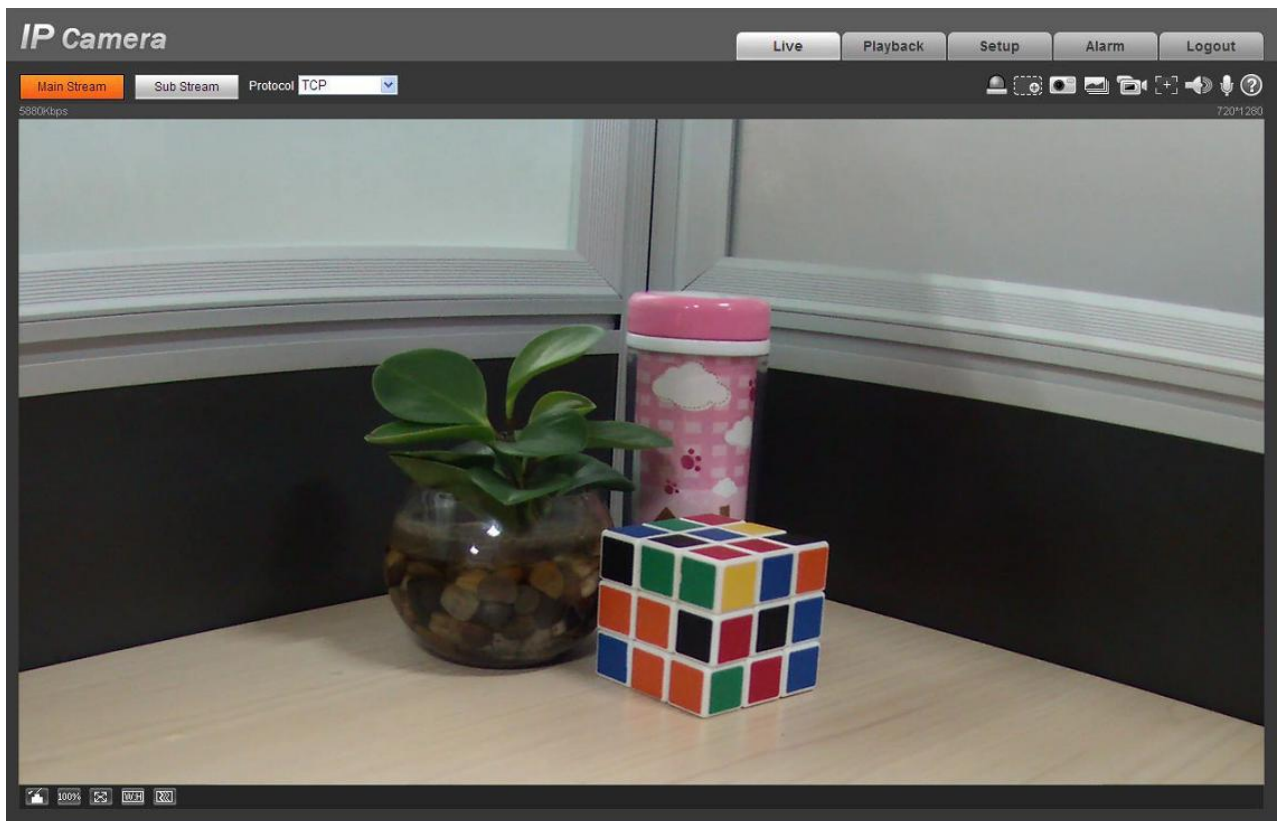

Figure 5- 3 Web monitoring window

Please refer to the Web Operation Manual included in the resource CD for detailed operation instruction.

6 FAQ

Bug	
I can not boot up the device.	Please click RESET button for at least five seconds to restore factory default setup.
SD card write times	Do not set the SD card as the storage media to storage the schedule record file. It may damage the SD card duration.
I can not use the disk as the storage media.	When disk information is shown as hibernation or capacity is 0, please format it first (Via Web).
I can not upgrade the device via network.	When network upgrade operation failed, you can use port 3800 to continue upgrade.
Recommended SD card brand	Kingston 4GB, Kingston 1GB, Kingston 16GB, Transcend 16GB, SanDisk 1G, SanDisk 4G Usually we recommend the 4GB (or higher) high speed card in case the slow speed results in data loss.
Audio function	Please use active device for the audio monitor input, otherwise there is no audio in the client-end.
To guarantee setup update	After you modified the important setup, please reboot the device via the software to make sure the setup has been updated to the storage medium.
Power adapter	The general power adapter included in the accessories bag can work ranging from 0°C to 40 °C. The device may result in unstable power supply when the temperature exceeds the working temperature. Please replace an industry-level power adapter if you are using in the harsh environments.

Appendix Toxic or Hazardous Materials or Elements

Component Name	Toxic or Hazardous Materials or Elements					
	Pb	Hg	Cd	Cr VI	PBB	PBDE
Circuit Board Component	○	○	○	○	○	○
Device Construction Material	○	○	○	○	○	○
Wire and Cable	○	○	○	○	○	○
Packing Components	○	○	○	○	○	○
Accessories	○	○	○	○	○	○

O: Indicates that the concentration of the hazardous substance in all homogeneous materials in the parts is below the relevant threshold of the SJ/T11363-2006 standard.

X: Indicates that the concentration of the hazardous substance of at least one of all homogeneous materials in the parts is above the relevant threshold of the SJ/T11363-2006 standard. During the environmental-friendly use period (EFUP) period, the toxic or hazardous substance or elements contained in products will not leak or mutate so that the use of these (substances or elements) will not result in any severe environmental pollution, any bodily injury or damage to any assets. The consumer is not authorized to process such kind of substances or elements, please return to the corresponding local authorities to process according to your local government statutes.

Note

- **This user's manual is for reference only. Slight difference may be found in user interface.**
- **All the designs and software here are subject to change without prior written notice.**
- **If there is any uncertainty or controversy, please refer to the final explanation of us.**
- **Please visit our website for more information.**
- **All trademarks and registered trademarks are the properties of their respective owners.**