

A Series HD Wi-Fi Network Camera Quick Start Guide

V 1.0.1

1 Packing List

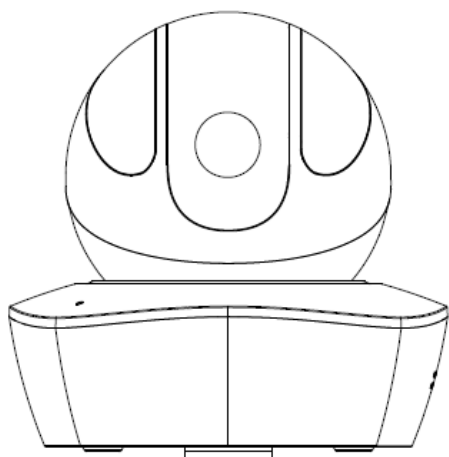

Device × 1

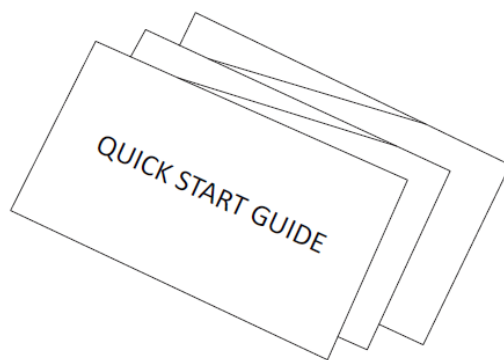

QSG × 1

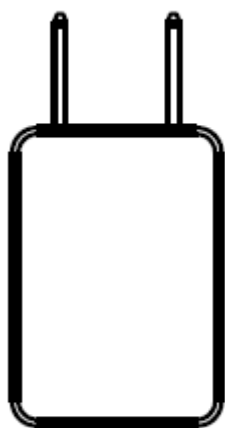

Power Adapter × 1

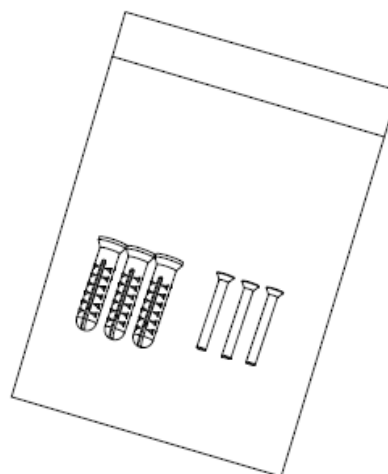

Screw Package × 1

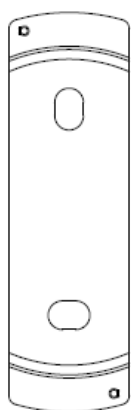

Quick Installation Board × 1

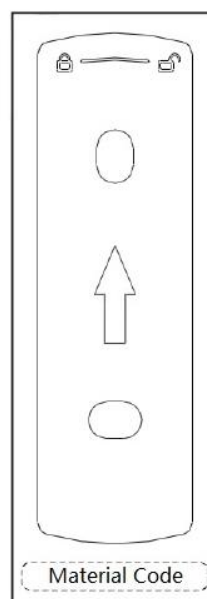

Installation Position Map × 1

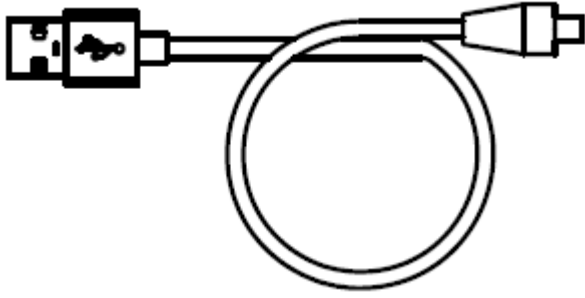

USB × 1

2 Product Appearance

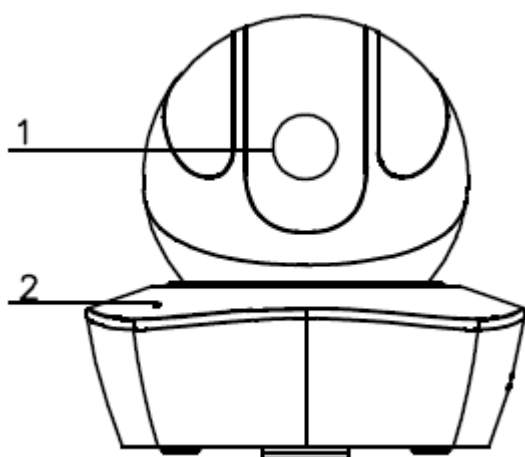

Figure 2-1

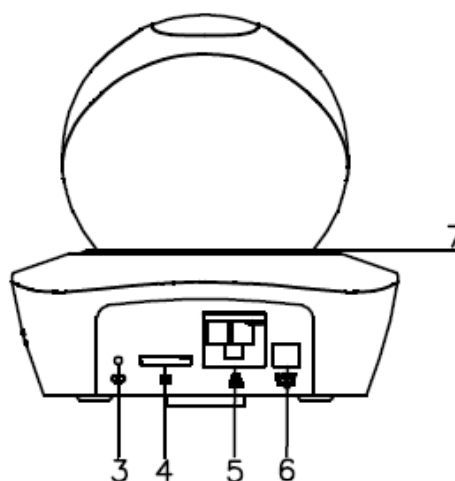

Figure 2-2

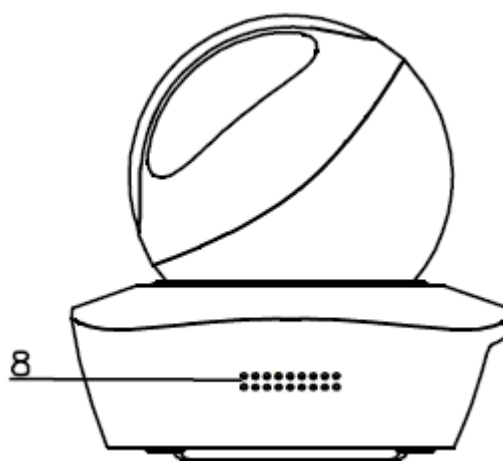

Figure 2-3

Please refer to the following sheet for more details about each port.

SN	Name
1	Lens
2	MIC
3	Reset/WPS (Wi-Fi Protected Setup) button
4	Micro SD card slot
5	Network port
6	Power port
7	Indicator light
8	Loudspeaker

Note:

For reset, long press for 8 seconds and then the light off; For WPS (Wi-Fi Protected Setup) one quick press.

Please refer to the following sheet for more details about status of indicator light.

Device status	Indicate light status
Red light spinning	Booting, device malfunction, fail to boot up
Green light spinning	Booting completed, await wifi config, enter smart config status;
Green light breathing	Wifi smart config in progress, including WPS (Wi-Fi Protected Setup), management frame and etc.
Blue light normally on	Wifi connection succeeded, operate normally.
Blue light flashing	Device upgrade
Yellow light breathing	Network connection failure or disconnection after network connection success.
Red light breathing	Alarm or SD card malfunction

Sheet 2-2

3 Operate by EasyViewer

Step 1

Power on the camera.

Step 2

Connect iPhone to a WiFi signal.

Step 3

Open EasyViewer (downloaded from APP Store), choose Device Manager.

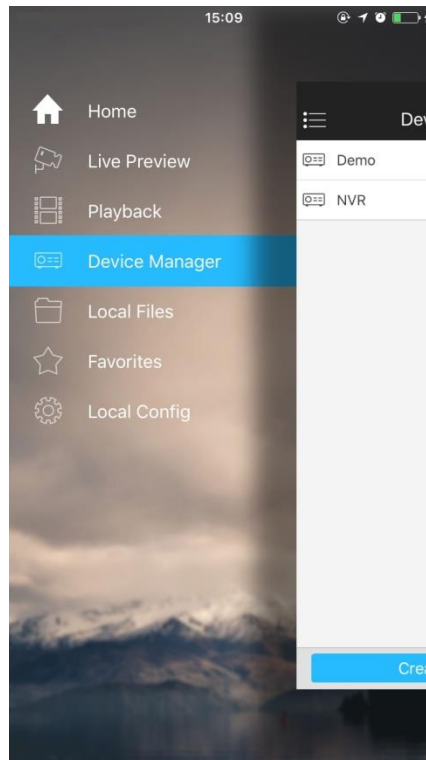

Figure 3-1

Step 4

Please select “P2P” when the network cable is connected, select “WiFi configuration” for wireless connection. Here is an example of wireless connection.

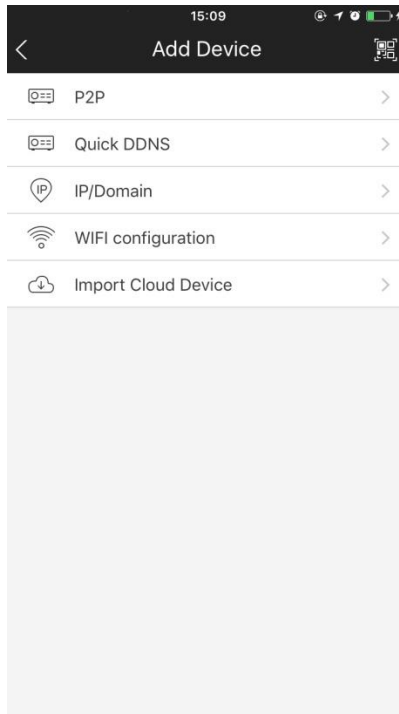

Figure 3-2

Step 5

Input a device name and scan the QR code (on the bottom of the device chassis) on camera, then “next”.

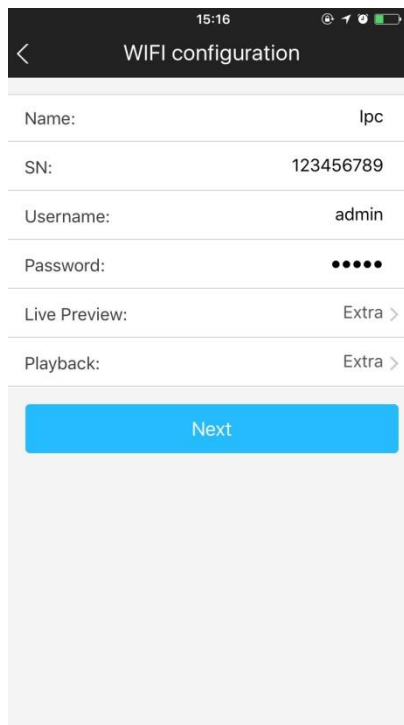

Figure 3-3

Step 6

Input the WiFi password, then “next”.

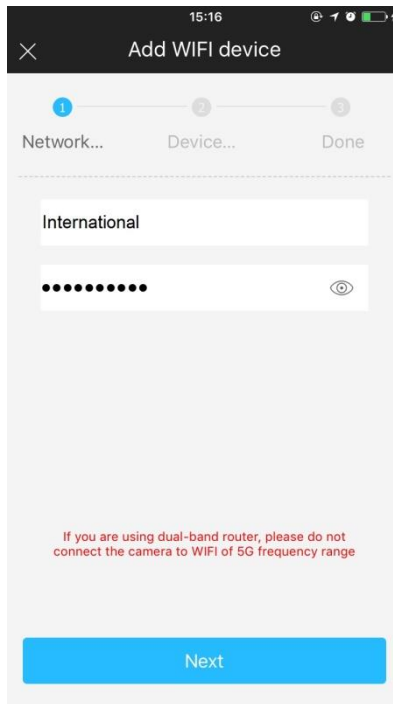

Figure 3-4

Step 7

Connection succeeds.

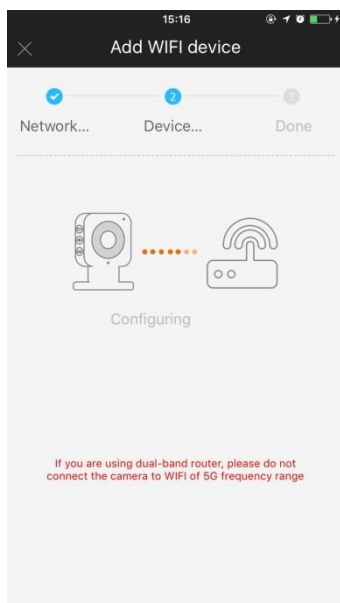

Figure 3-5

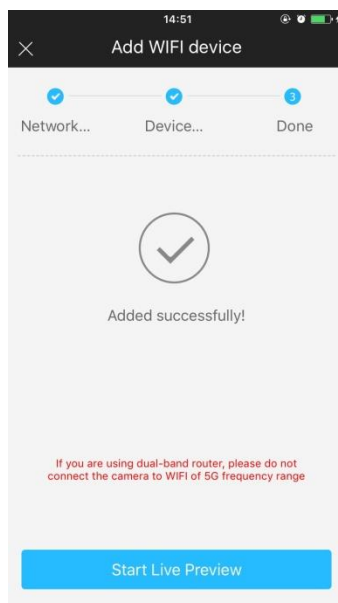

Figure 3-6

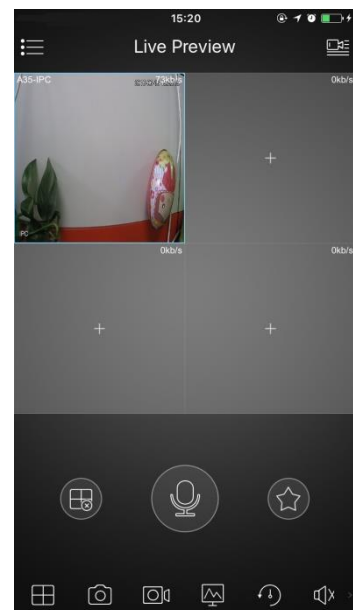

Figure 3-7

Note:

Please try again or check the WiFi password if it failed.

The WiFi configuration will be closed if activating WPS (WI-FI Protected Setup) function; Please reset the device if you still need to configure WiFi via EasyViewer.

4 Device Installation

Important

Before the installation, please make sure the installation environments can at least support 3x weight of the camera.

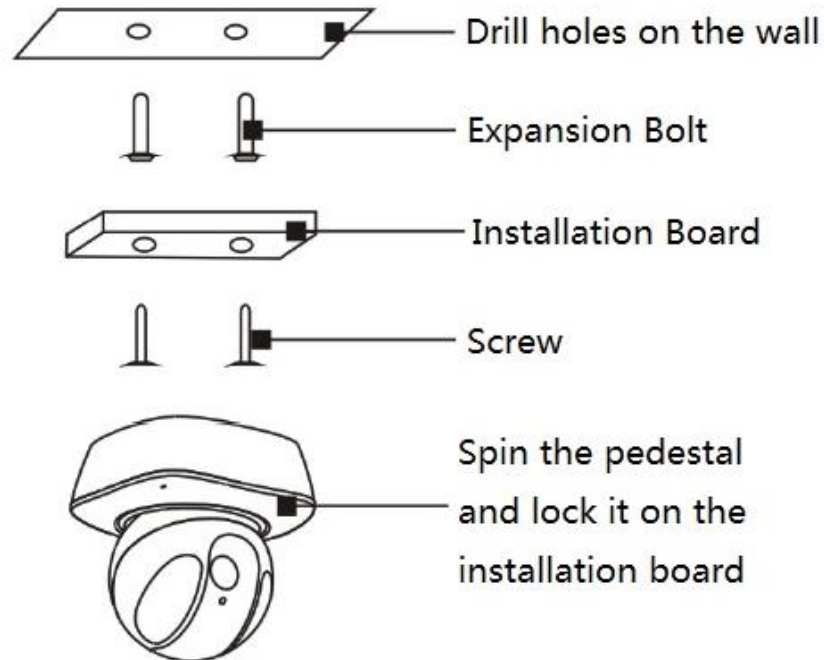

Figure 4-1

Note:

- This quick start guide is for reference only. Slight difference may be found in user interface.
- All the designs and software here are subject to change without prior written notice.
- All trademarks and registered trademarks mentioned are the properties of their respective owners.
- If there is any uncertainty or controversy, please refer to the final explanation of us.
- Please visit our website or contact your local service engineer for more information.